

# 05075200 - LT-A D55 ER32F-32F H100 BI

<b>Type</b>	LT-A DBL Tool holder double angle 90°
<b>Mounting</b>	CYLINDRICAL SHANK 55
<b>Tool output</b>	Collet nut ER 32 F - internal nut
<b>Coolant</b>	External coolant
<b>Direction of rotation</b>	r1 ↻ r2 ↻ r3 ↻
<b>Max speed [rpm]</b>	6000
<b>Max torque [Nm]</b>	63
<b>Ratio</b>	1:1
<b>H [mm]</b>	100
<b>H1 [mm]</b>	38
<b>Accessories</b>	N.A.
<b>Notes</b>	N.A.
<b>Mounting tips</b>	Main and secondary spindle

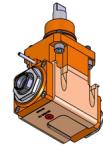

Always check live tool dimensions on the turret

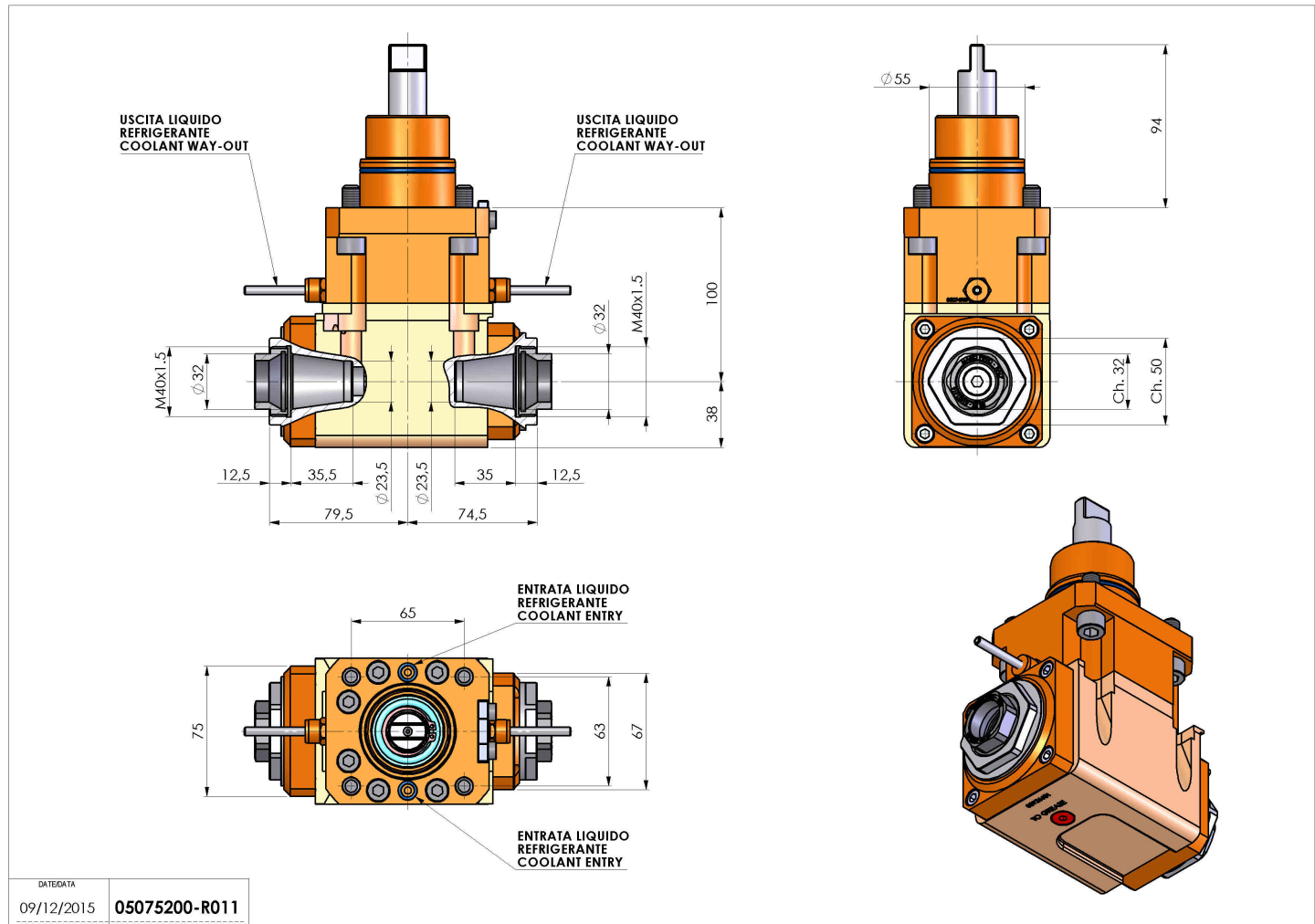

DATE/DATE	09/12/2015	05075200-R011
-----------	------------	---------------

Subject to technical changes