

05071200 - LT-A D40 ER20 LR HRF H70 BI

| | |
|-----------------------|-------------------------------|
| Type | LT-A Tool holder angle 90° |
| Mounting | CYLINDRICAL SHANK 40 |
| Tool output | Collet nut ER 20 |
| Coolant | HRF Internal coolant |
| Direction of rotation | r1 ↻ r2 ↻ |
| Max speed [rpm] | 6000 |
| Max torque [Nm] | 22 |
| Ratio | 1:1 |
| H [mm] | 70 |
| H1 [mm] | 22 |
| Max pressure [bar] | 80 |
| Accessories | N.A. |
| Notes | N.A. |
| Mounting tips | Main and secondary spindle |

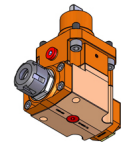

Always check live tool dimensions on the turret

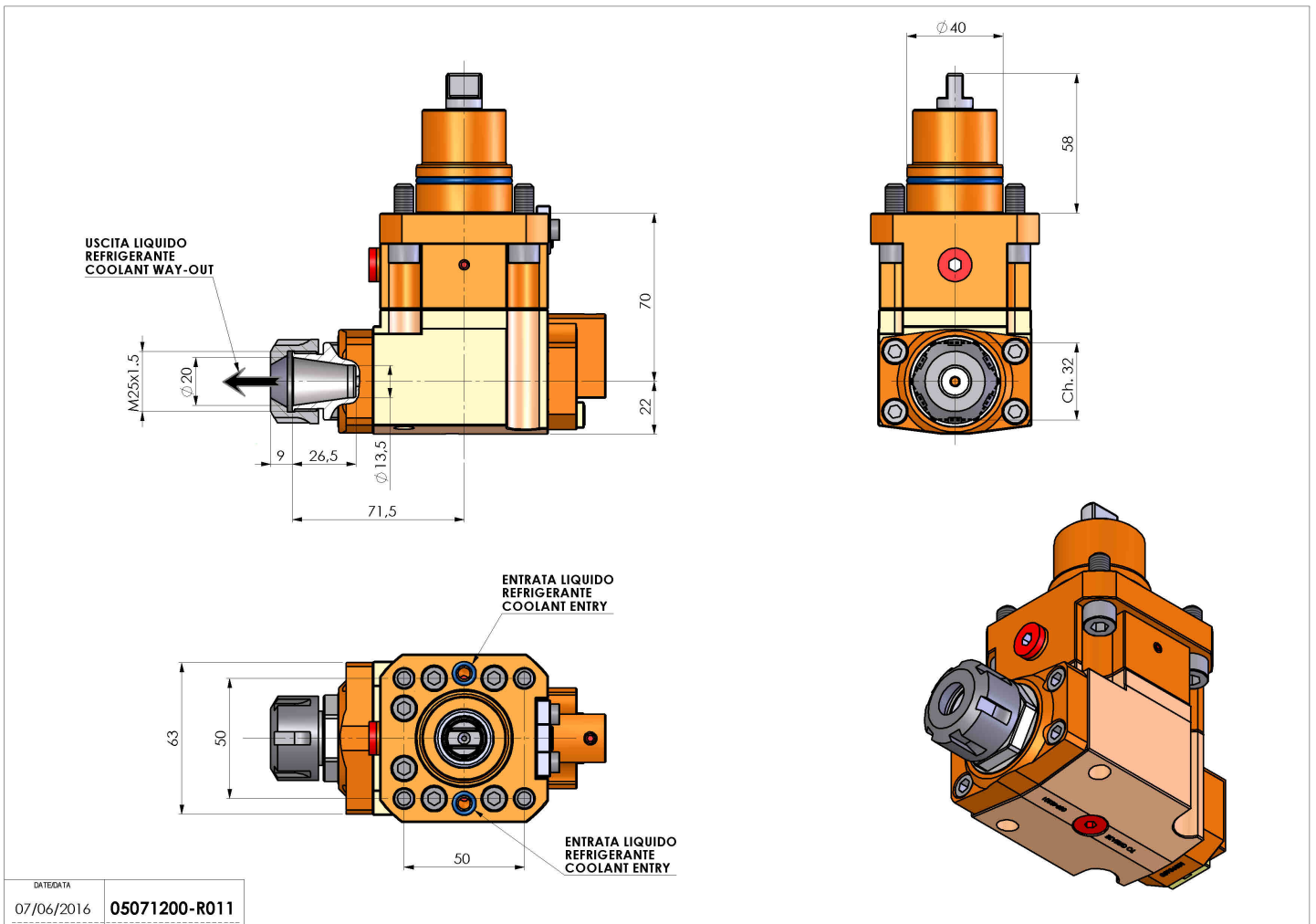

DATE/DATE: 07/06/2016
05071200-R011

Subject to technical changes