

05070700 - LT-A D40 ER20 LR H70 BI

Type	LT-A Tool holder angle 90°
Mounting	CYLINDRICAL SHANK 40
Tool output	Collet nut ER 20
Coolant	External coolant
Direction of rotation	r1 ↻ r2 ↻
Max speed [rpm]	6000
Max torque [Nm]	22
Ratio	1:1
H [mm]	70
H1 [mm]	22
Accessories	N.A.
Notes	N.A.
Mounting tips	Main and secondary spindle

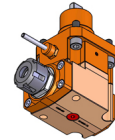

Always check live tool dimensions on the turret

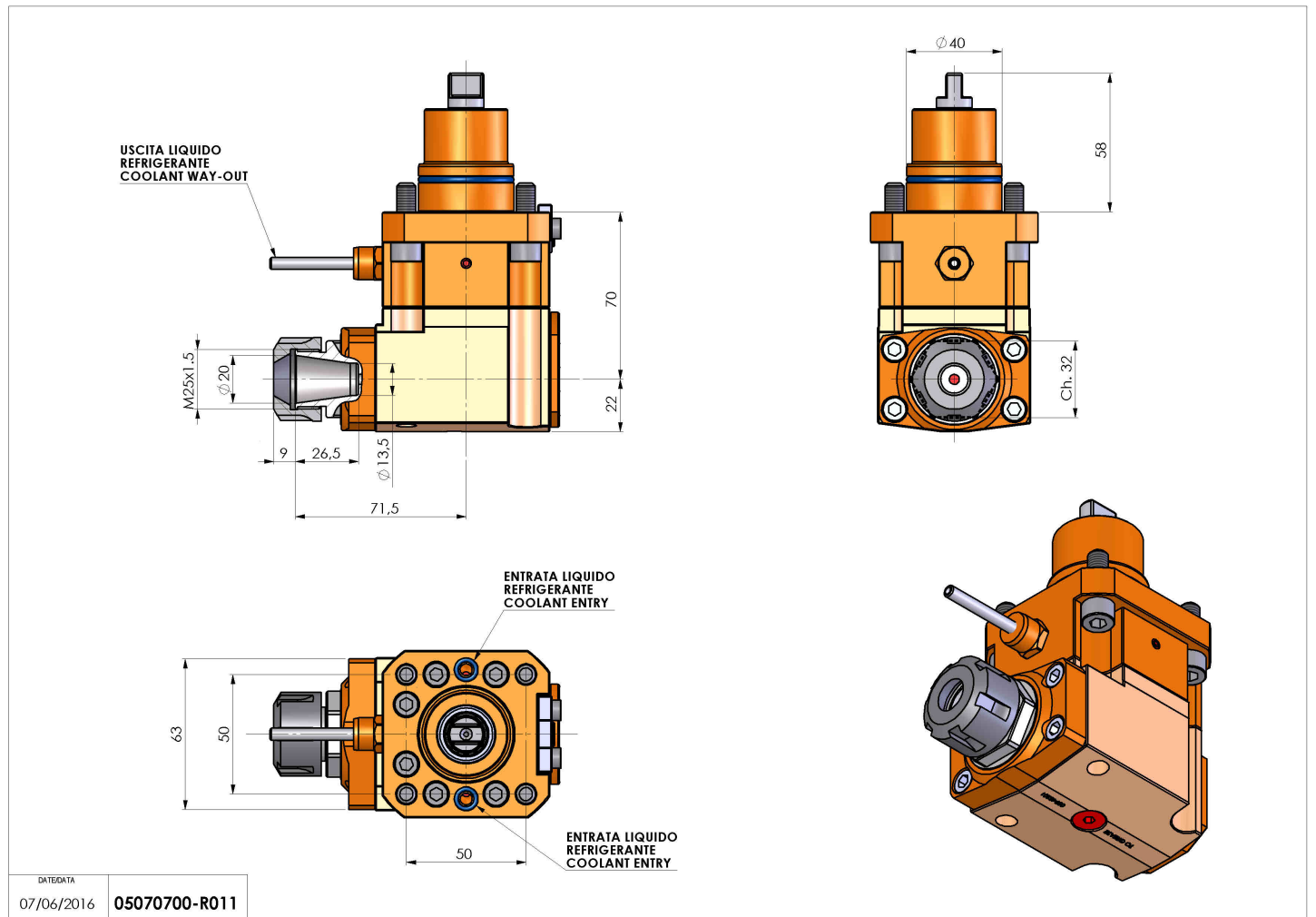

DATE/DATE: 07/06/2016
05070700-R011

Subject to technical changes