

05061600 - LT-SVDI40 DIN138-16 OF51 2:1 H97 OK

Type	LT-S OFS Tool holder straight offset
Mounting	VDI 40
Tool output	Shell-Mill DIN138 16
Coolant	External coolant
Offset [mm]	51
Direction of rotation	r1 r2
Max speed [rpm]	in 5000 / out 2500
Max torque [Nm]	in 60 / out 120
Ratio	2:1
H [mm]	97
Accessories	N.A.
Notes	N.A.
Mounting tips	Secondary spindle only

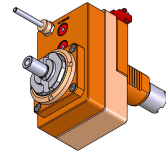

ATTENTION: CHECK THE ORIENTATION OF THE VDI TEETH

Always check live tool dimensions on the turret

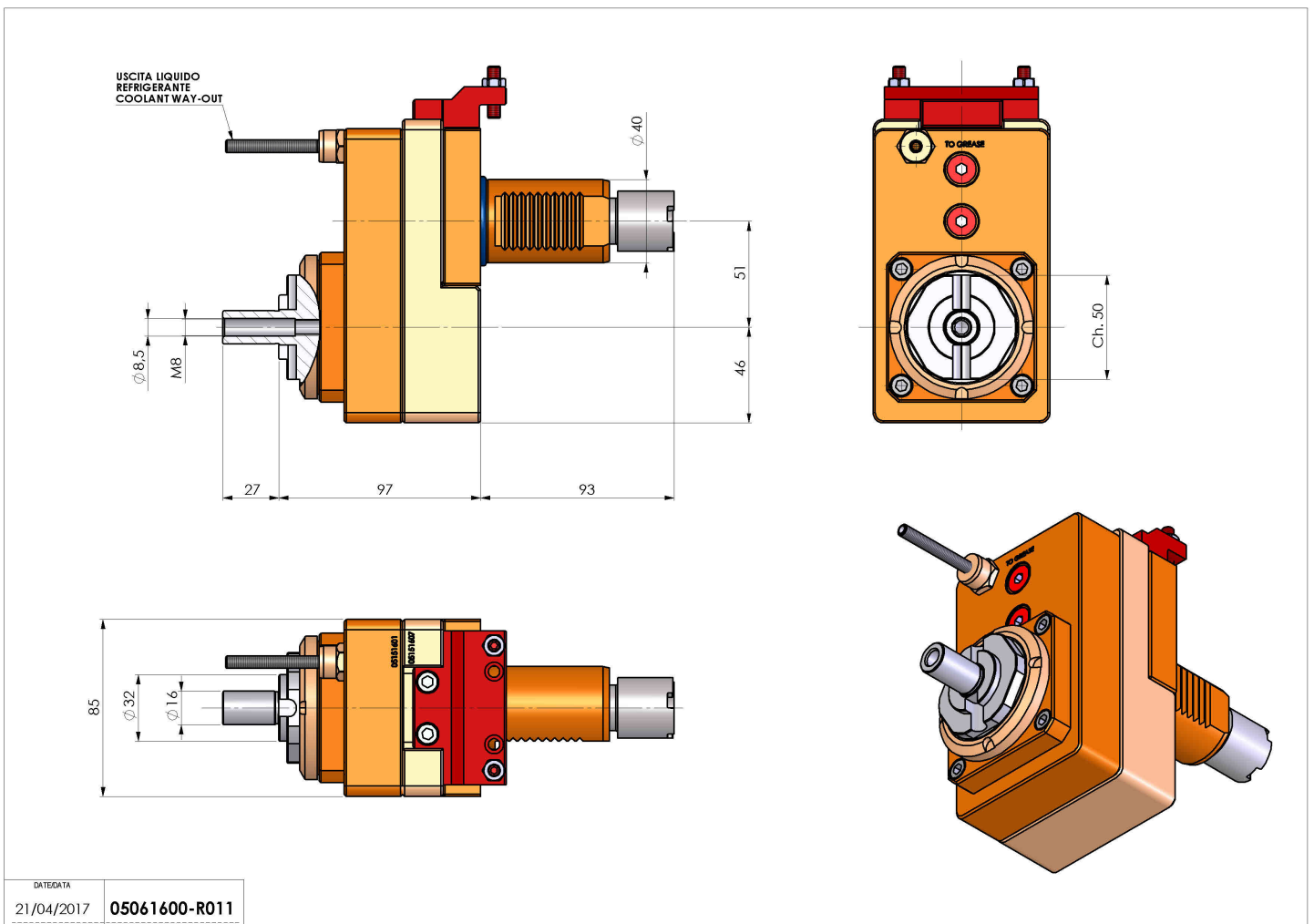

DATE/DATE	05061600-R011
21/04/2017	

Subject to technical changes