

05059800 - LT-S VDI50ER32OFS60 1:2 KRH145

Type	LT-S OFS Tool holder straight offset
Mounting	VDI 50
Tool output	Collet nut ER 32
Coolant	With coolant kit
Offset [mm]	60
Direction of rotation	r1 ↻ r2 ↻
Max speed [rpm]	in 6000 / out 12000
Max torque [Nm]	in 160 / out 80
Ratio	1:2
H [mm]	145
Accessories	N.A.
Notes	N.A.
Mounting tips	N.A.

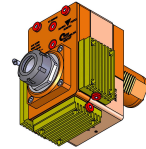

ATTENTION: CHECK THE ORIENTATION OF THE VDI TEETH

Always check live tool dimensions on the turret

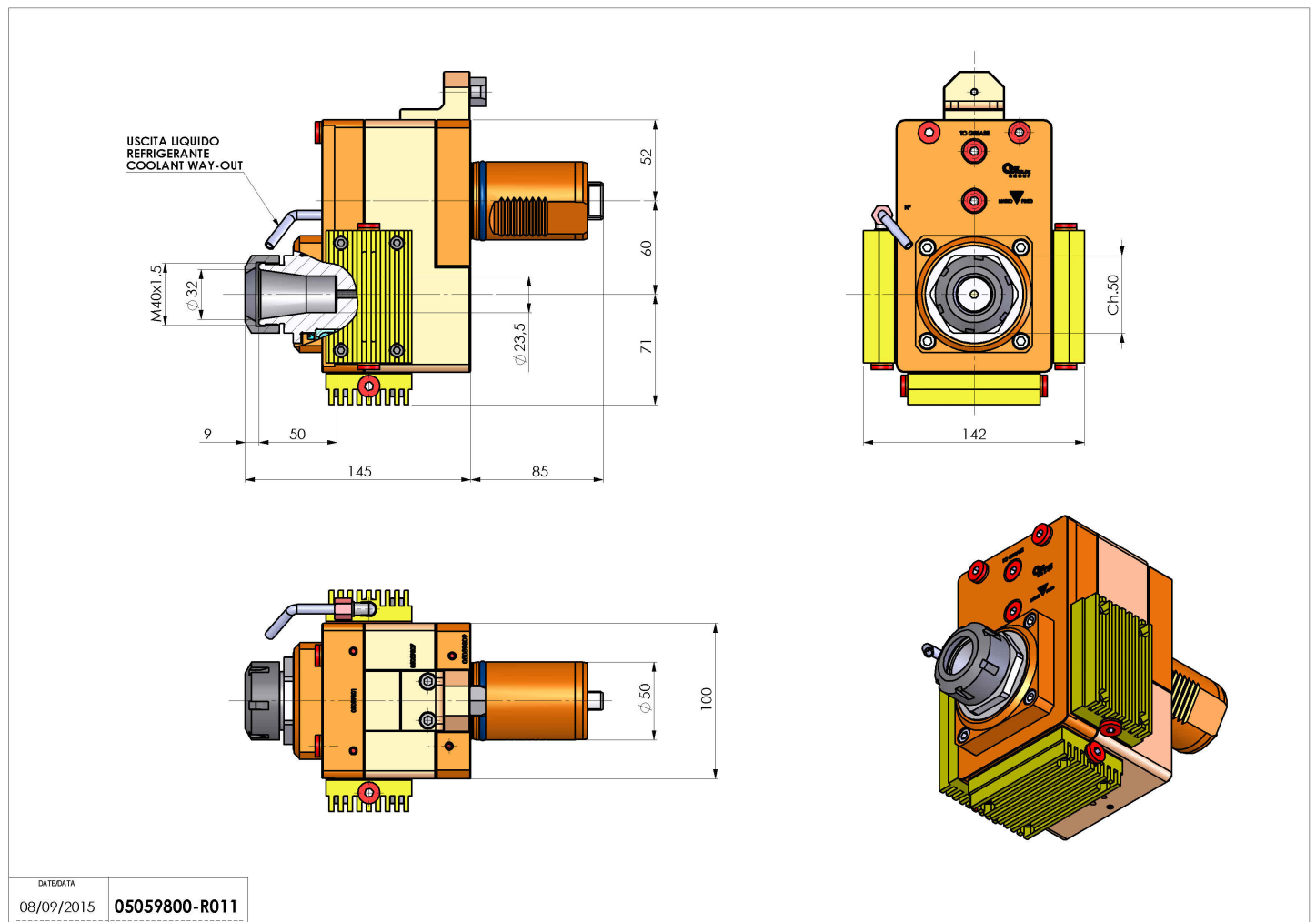

DATE/DATE	08/09/2015	05059800-R011
-----------	------------	---------------

Subject to technical changes