

05059400 - LT-A VDI50 ISOBT40LRF2:1H160MZ

Type	LT-A Tool holder angle 90°
Mounting	VDI 50
Tool output	Quick Change ISO-BT40
Coolant	Internal coolant
Direction of rotation	r1 ↻ r2 ↻
Max speed [rpm]	in 6000 / out 3000
Max torque [Nm]	in 60/ out 120
Ratio	2:1
H [mm]	160
H1 [mm]	52
Max pressure [bar]	20
Accessories	N.A.
Notes	N.A.
Mounting tips	N.A.

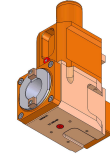

ATTENTION: CHECK THE ORIENTATION OF THE VDI TEETH

Always check live tool dimensions on the turret

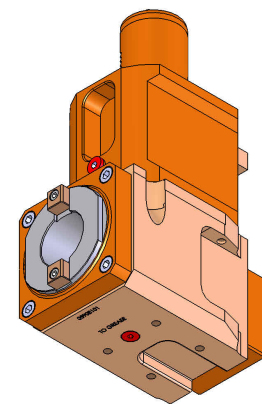
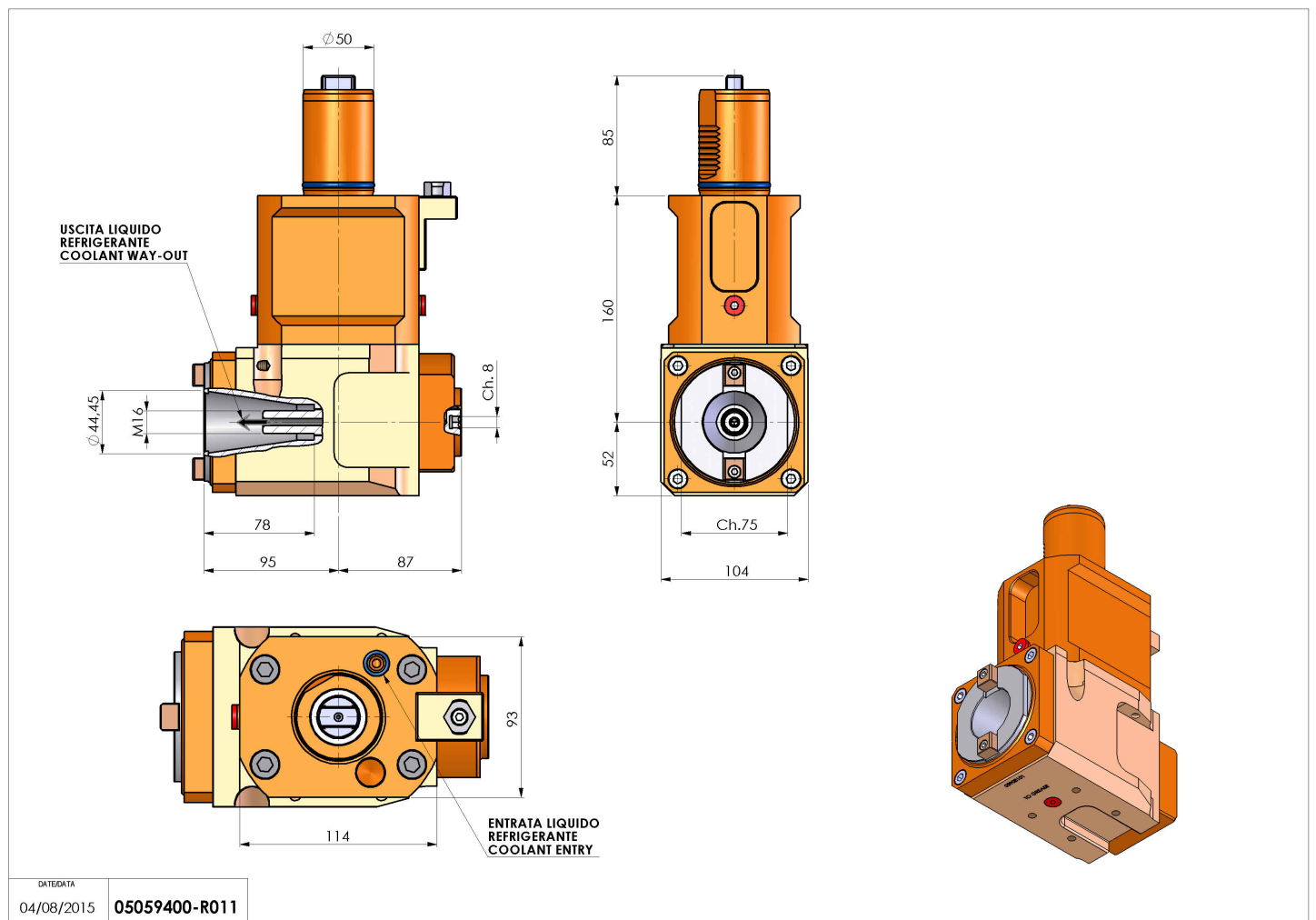

Subject to technical changes