

05059100 - LT-S VDI50ISOBT40OFS76RFH105MZ

Type	LT-S OFS Tool holder straight offset
Mounting	VDI 50
Tool output	Quick Change ISO-BT40
Coolant	Internal coolant
Offset [mm]	76
Direction of rotation	r1 ↻ r2 ↻
Max speed [rpm]	6000
Max torque [Nm]	180
Ratio	1:1
H [mm]	105
Max pressure [bar]	20
Accessories	N.A.
Notes	N.A.
Mounting tips	N.A.

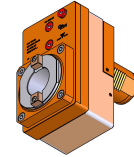

ATTENTION: CHECK THE ORIENTATION OF THE VDI TEETH

Always check live tool dimensions on the turret

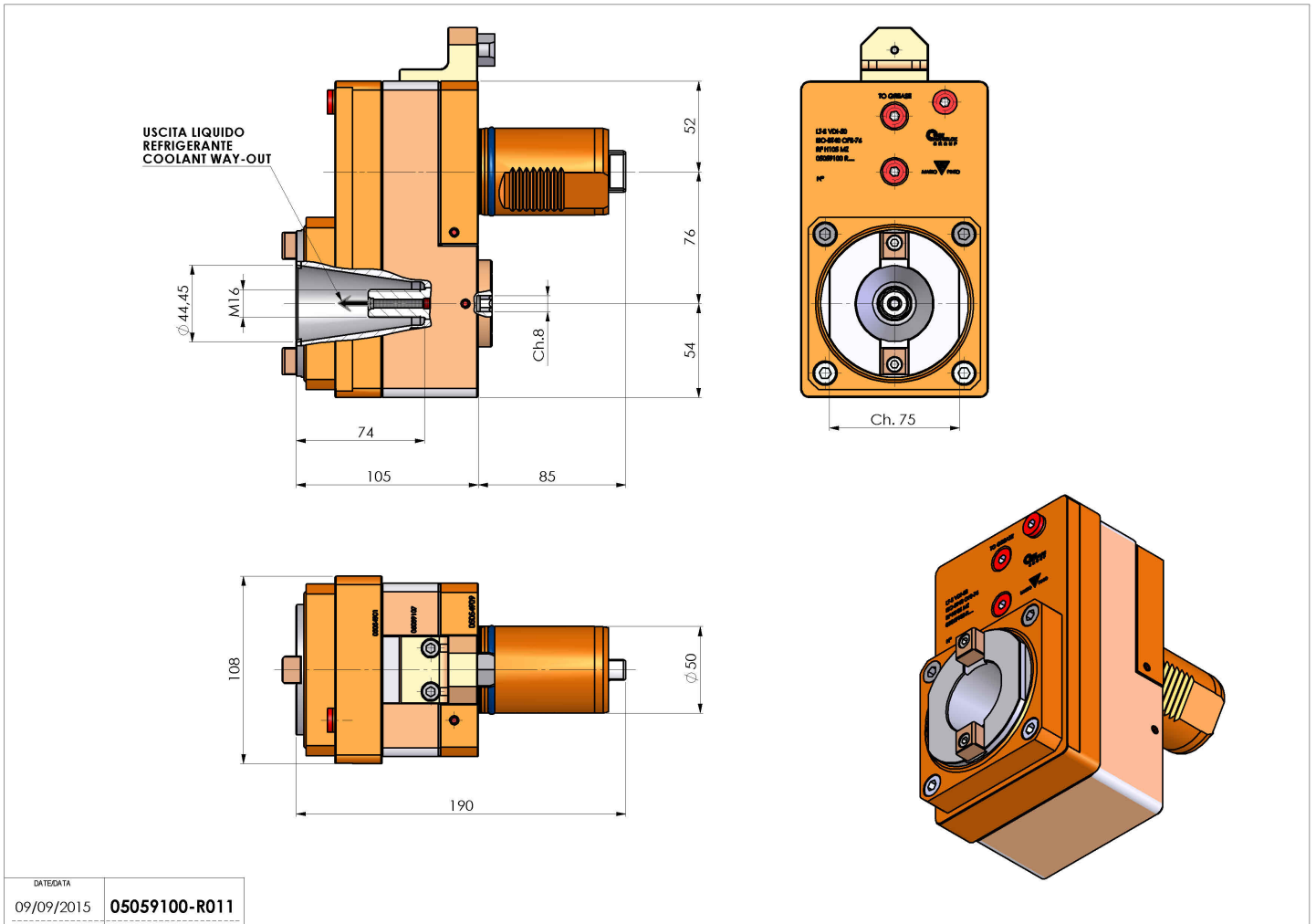

DATE/DATE	09/09/2015
05059100-R011	

Subject to technical changes