

## 05057400 - LT-S VDI40 DIN22 OF50 G60 MLMZ

Type	LT-S OFS Tool holder straight offset
Mounting	VDI 40
Tool output	Shell-Mill DIN138 22
Coolant	External coolant
Offset [mm]	50
Direction of rotation	r1 ↻ r2 ↻
Max speed [rpm]	6000
Max torque [Nm]	63
Ratio	1:1
H [mm]	110
Accessories	N.A.
Notes	N.A.
Mounting tips	N.A.

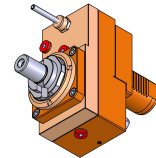

**ATTENTION: CHECK THE ORIENTATION OF THE VDI TEETH**

Always check live tool dimensions on the turret

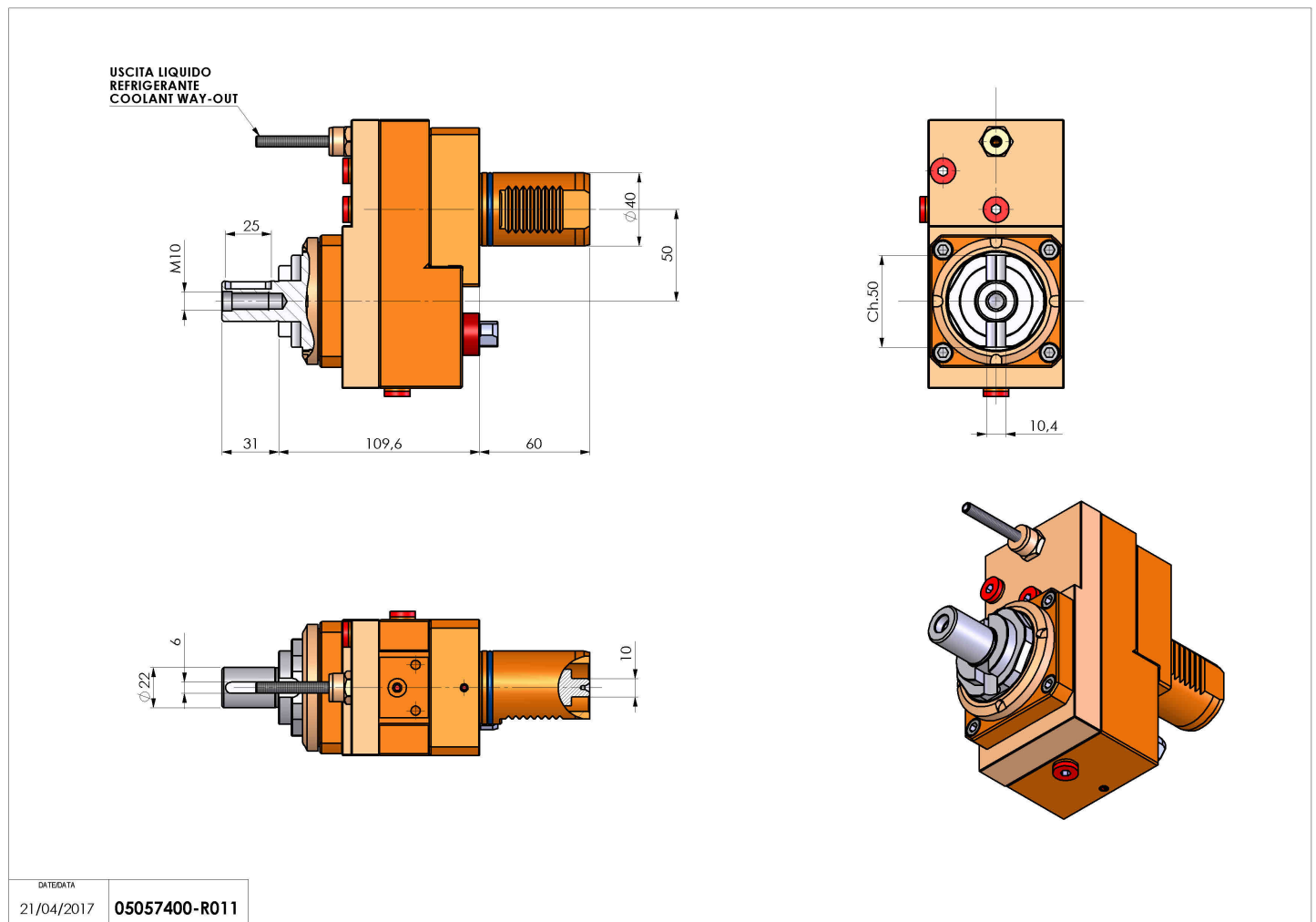

DATE/ATA	05057400-R011
21/04/2017	

Subject to technical changes