

## 05055600 - LT-S VDI40 DIN138-16 H70 G60 MZ

Type	LT-S Tool holder straight
Mounting	VDI 40
Tool output	Shell-Mill DIN138 16
Coolant	External coolant
Direction of rotation	r1 ↻ r2 ↻
Max speed [rpm]	6000
Max torque [Nm]	63
Ratio	1:1
H [mm]	70
Accessories	
Notes	N.A.
Mounting tips	N.A.

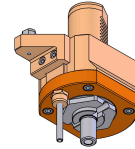

**ATTENTION: CHECK THE ORIENTATION OF THE VDI TEETH**

Always check live tool dimensions on the turret

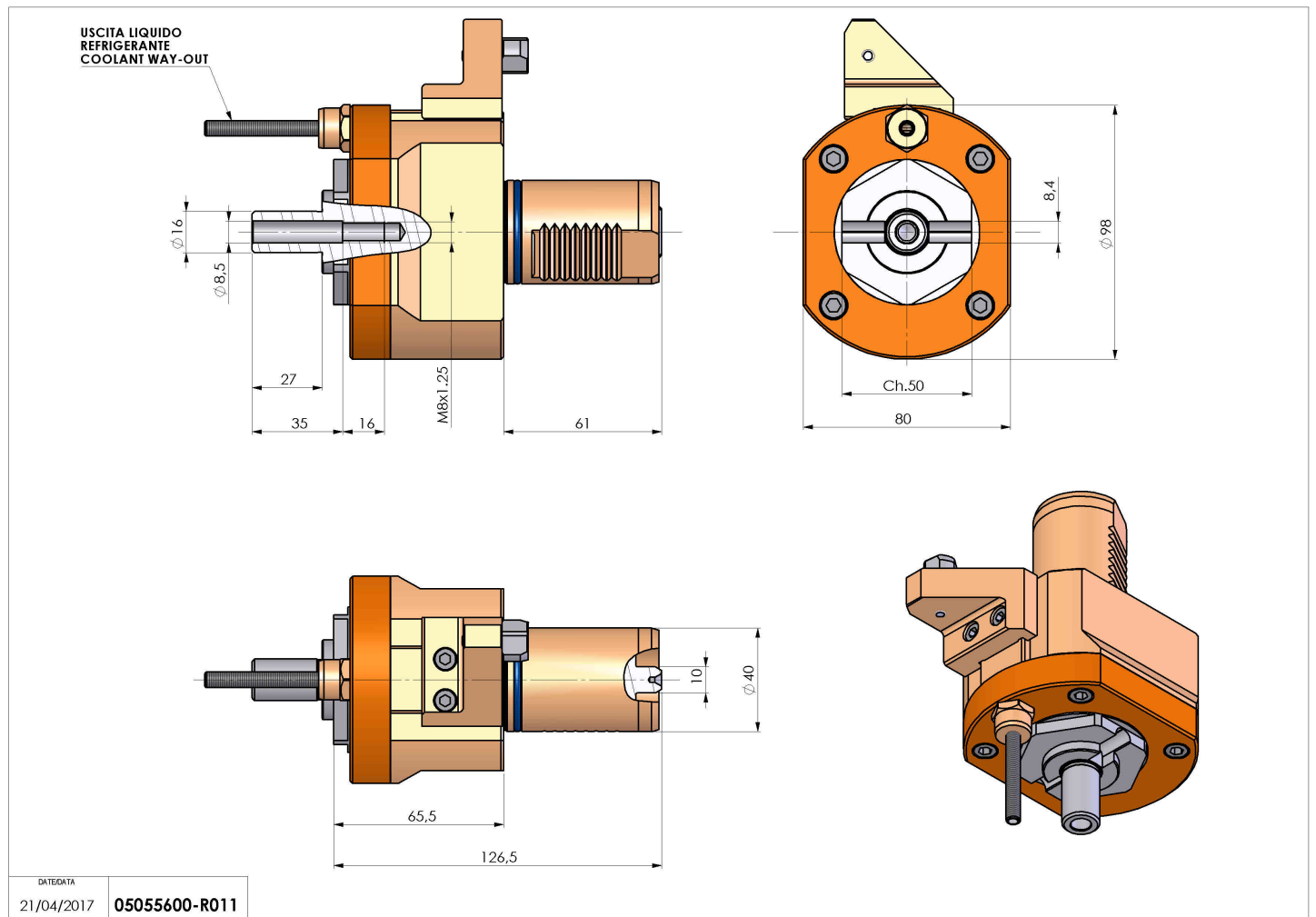

DATE/DATE  
21/04/2017 05055600-R011

Subject to technical changes