

## 05054400 - LT-A VDI50 DIN138-27 L H160 MZ

Type	LT-A Tool holder angle 90°
Mounting	VDI 50
Tool output	Shell-Mill DIN138 27
Coolant	External coolant
Direction of rotation	r1 ↻ r2 ↻
Max speed [rpm]	6000
Max torque [Nm]	63
Ratio	1:1
H [mm]	160
H1 [mm]	43
Accessories	N.A.
Notes	N.A.
Mounting tips	N.A.

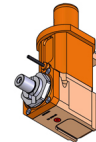

**ATTENTION: CHECK THE ORIENTATION OF THE VDI TEETH**

Always check live tool dimensions on the turret

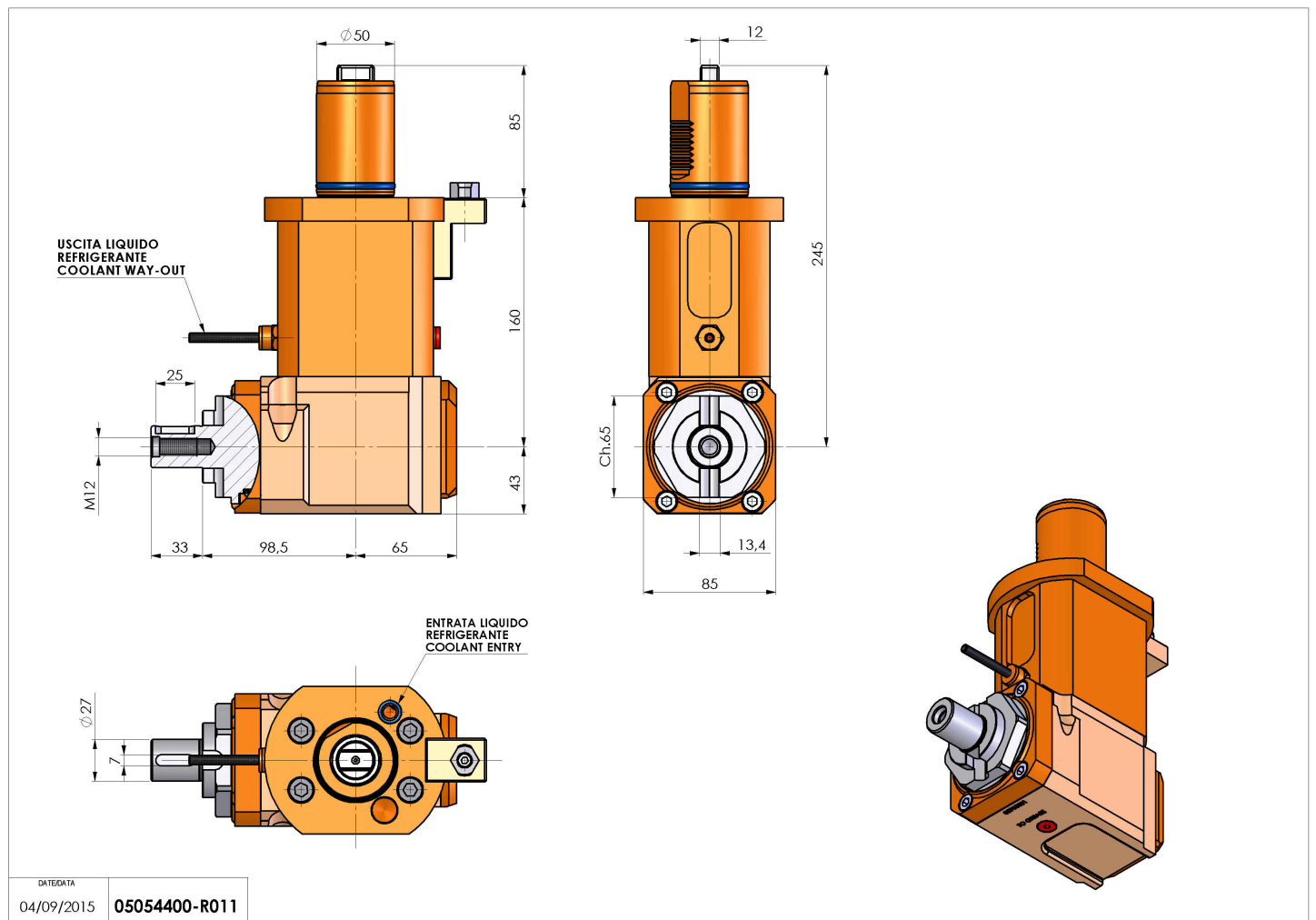

DATE/ATA  
04/09/2015 05054400-R011

Subject to technical changes