

05049600 - LT-A D60 ER40 L-R 2:1 H90

Type	LT-A Tool holder angle 90°
Mounting	CYLINDRICAL SHANK 60
Tool output	Collet nut ER 40
Coolant	External coolant
Direction of rotation	r1 ↻ r2 ↻
Max speed [rpm]	in 6000 / out 3000
Max torque [Nm]	in 60 / out 120
Ratio	2:1
H [mm]	90
H1 [mm]	43
Accessories	N.A.
Notes	N.A.
Mounting tips	N.A.

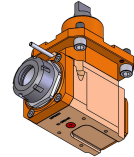

Always check live tool dimensions on the turret

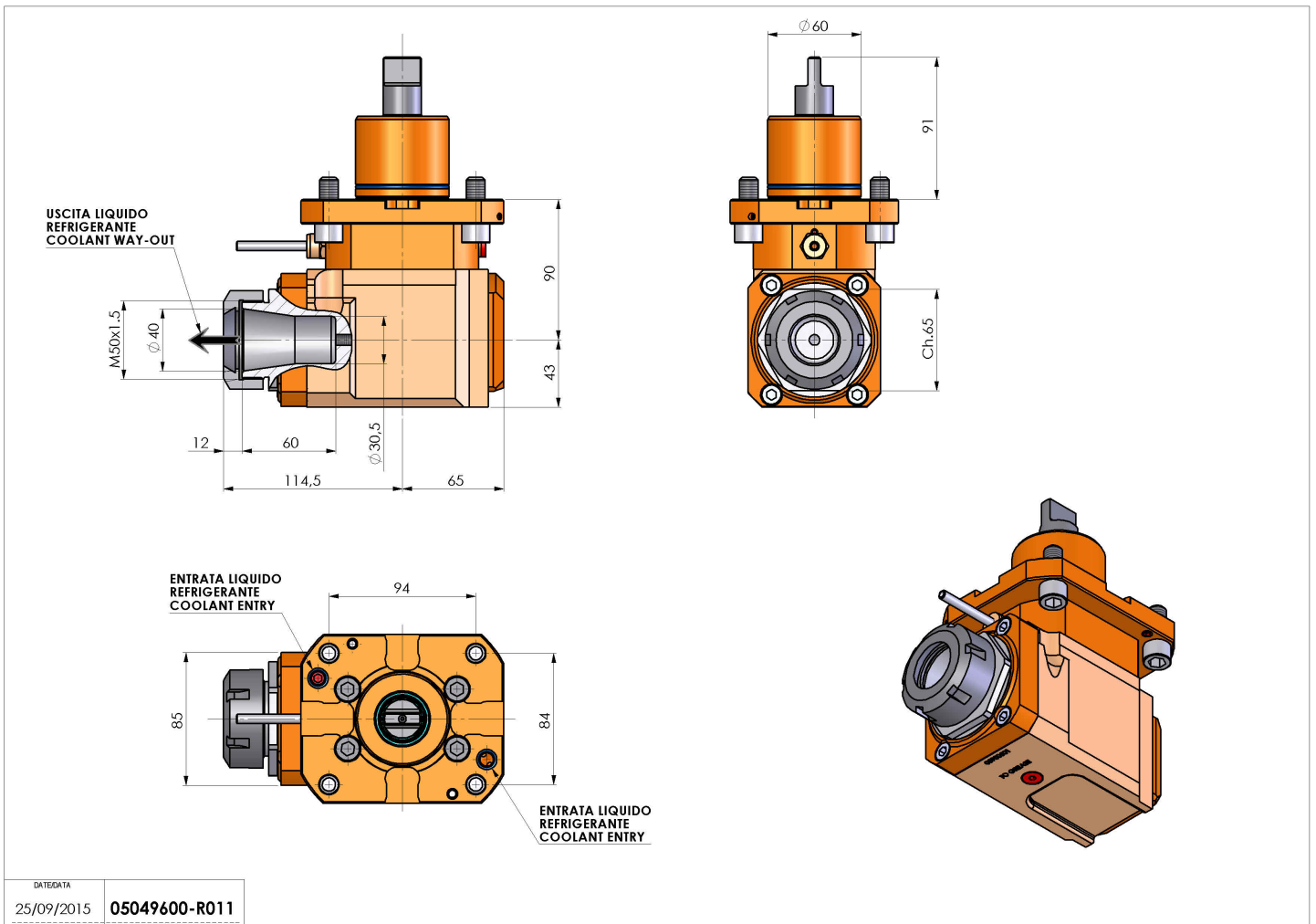

DATE/DATE	05049600-R011
25/09/2015	

Subject to technical changes