



05046700 - LT-A D60 HSK63 LR HRFHS H90

Type	LT-A Tool holder angle 90°
Mounting	CYLINDRICAL SHANK 60
Tool output	Quick Change HSK63
Coolant	HRF Internal coolant
Direction of rotation	r1  r2 
Max speed [rpm]	10000
Max torque [Nm]	63
Ratio	1:1
H [mm]	90
H1 [mm]	43
Max pressure [bar]	80
Accessories	N.A.
Notes	N.A.
Mounting tips	N.A.



Always check live tool dimensions on the turret

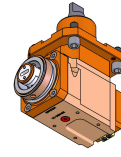
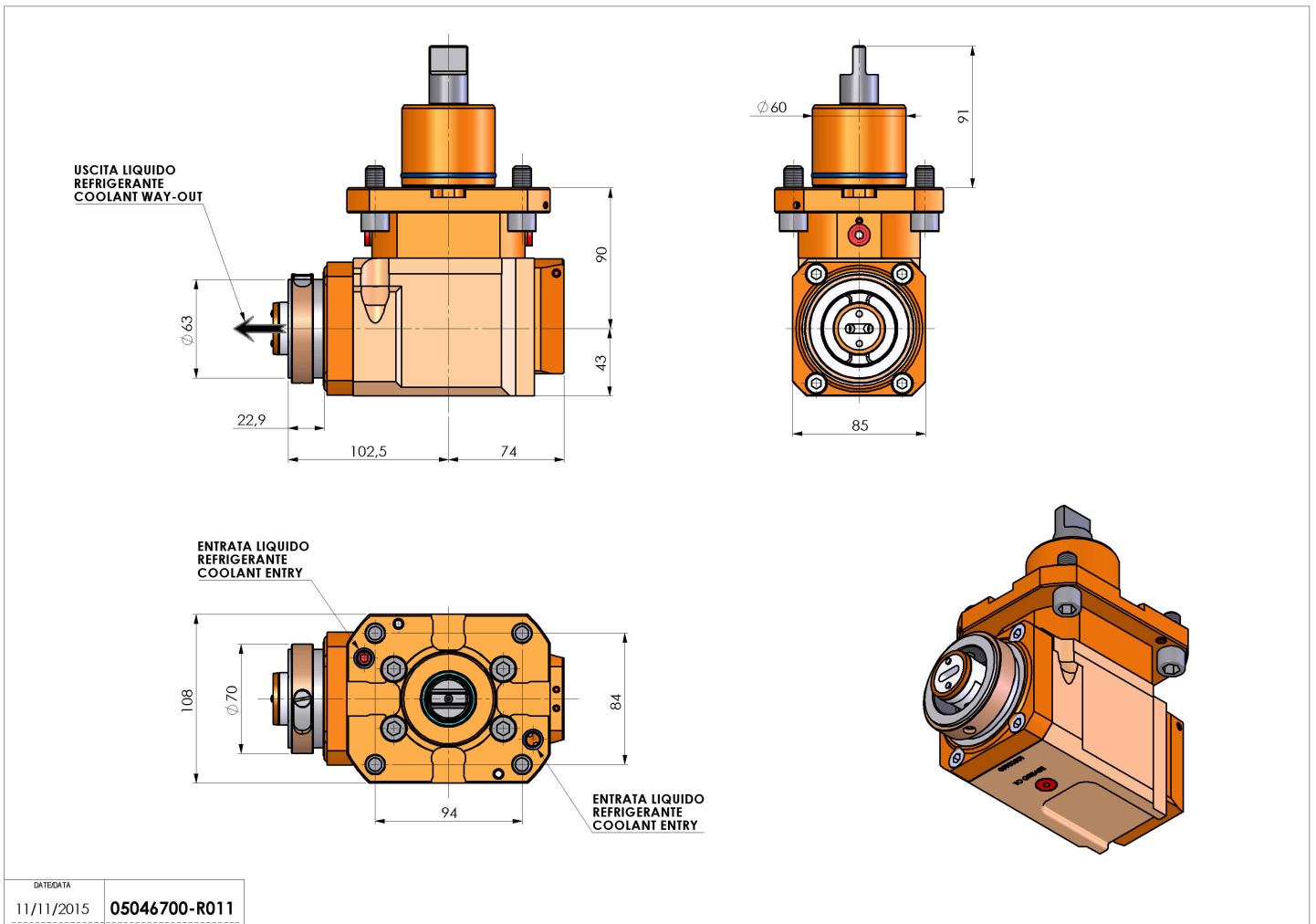

DATE/DATE	05046700-R011
11/11/2015	

Subject to technical changes