

# 05046500 - LT-A D60 ER32F-32F LR2:1H90 MS

<b>Type</b>	LT-A DBL Tool holder double angle 90°
<b>Mounting</b>	CYLINDRICAL SHANK 60
<b>Tool output</b>	Collet nut ER 32 F - internal nut
<b>Coolant</b>	External coolant
<b>Direction of rotation</b>	r1 ↻ r2 ↻ r3 ↻
<b>Max speed [rpm]</b>	in 10000 / out 5000
<b>Max torque [Nm]</b>	in 60 / out 120
<b>Ratio</b>	2:1
<b>H [mm]</b>	90
<b>H1 [mm]</b>	37,5
<b>Accessories</b>	N.A.
<b>Notes</b>	N.A.
<b>Mounting tips</b>	N.A.

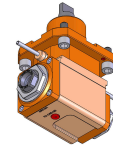

Always check live tool dimensions on the turret

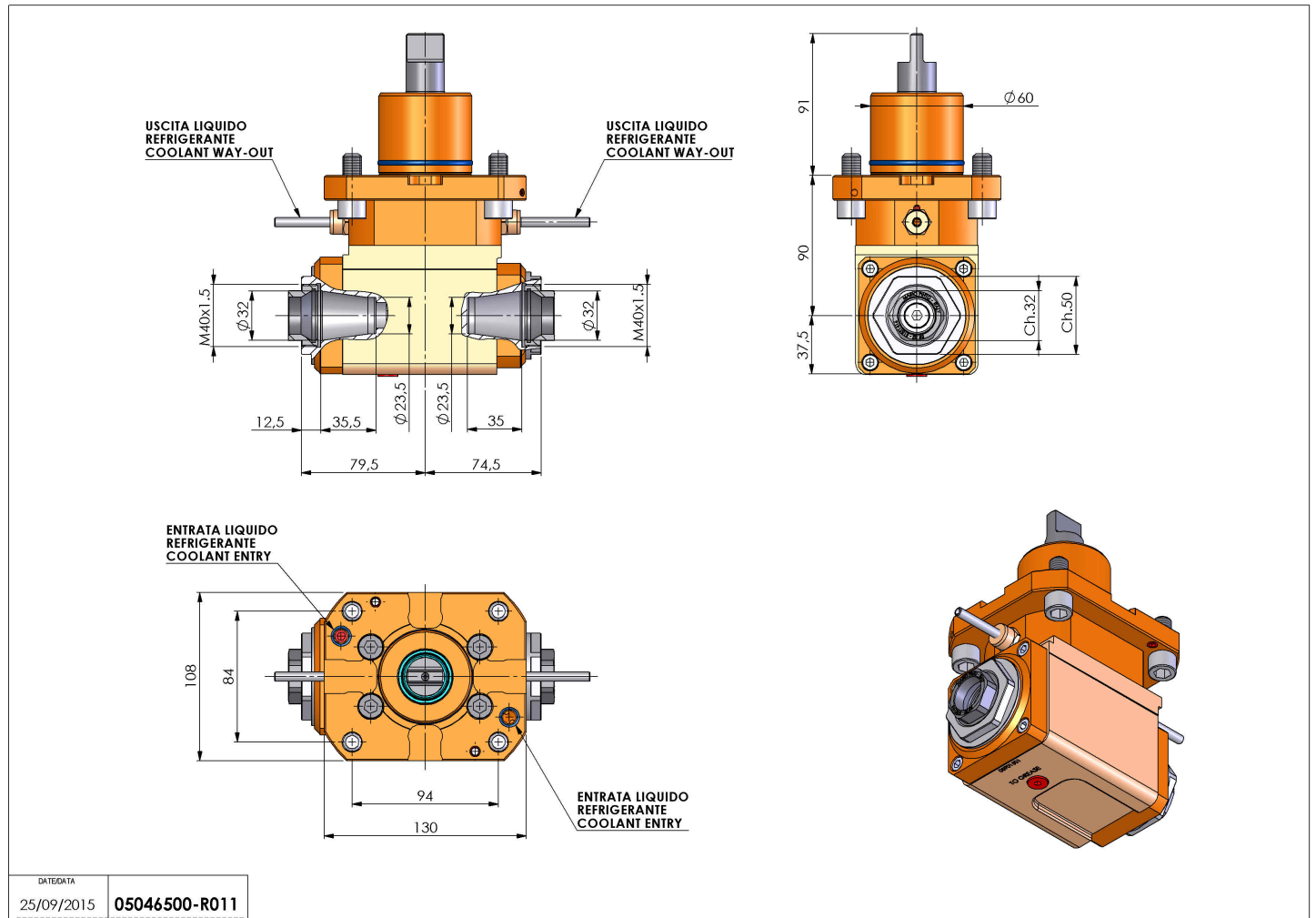

DATE/DATE	05046500-R011
25/09/2015	

Subject to technical changes