

05043300 - LT-A2H D40 ER20 I:50 1:1 H101

Type	LT-A2 H Tool holder angle 90° double horizontal
Mounting	CYLINDRICAL SHANK 40
Tool output	Collet nut ER 20
Coolant	External coolant
Direction of rotation	r1 ↻ r2 ↻
Max speed [rpm]	6000
Max torque [Nm]	20
Ratio	1:1
H [mm]	101
H1 [mm]	28
Accessories	N.A.
Notes	N.A.
Mounting tips	N.A.

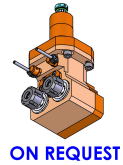

ON REQUEST

Always check live tool dimensions on the turret

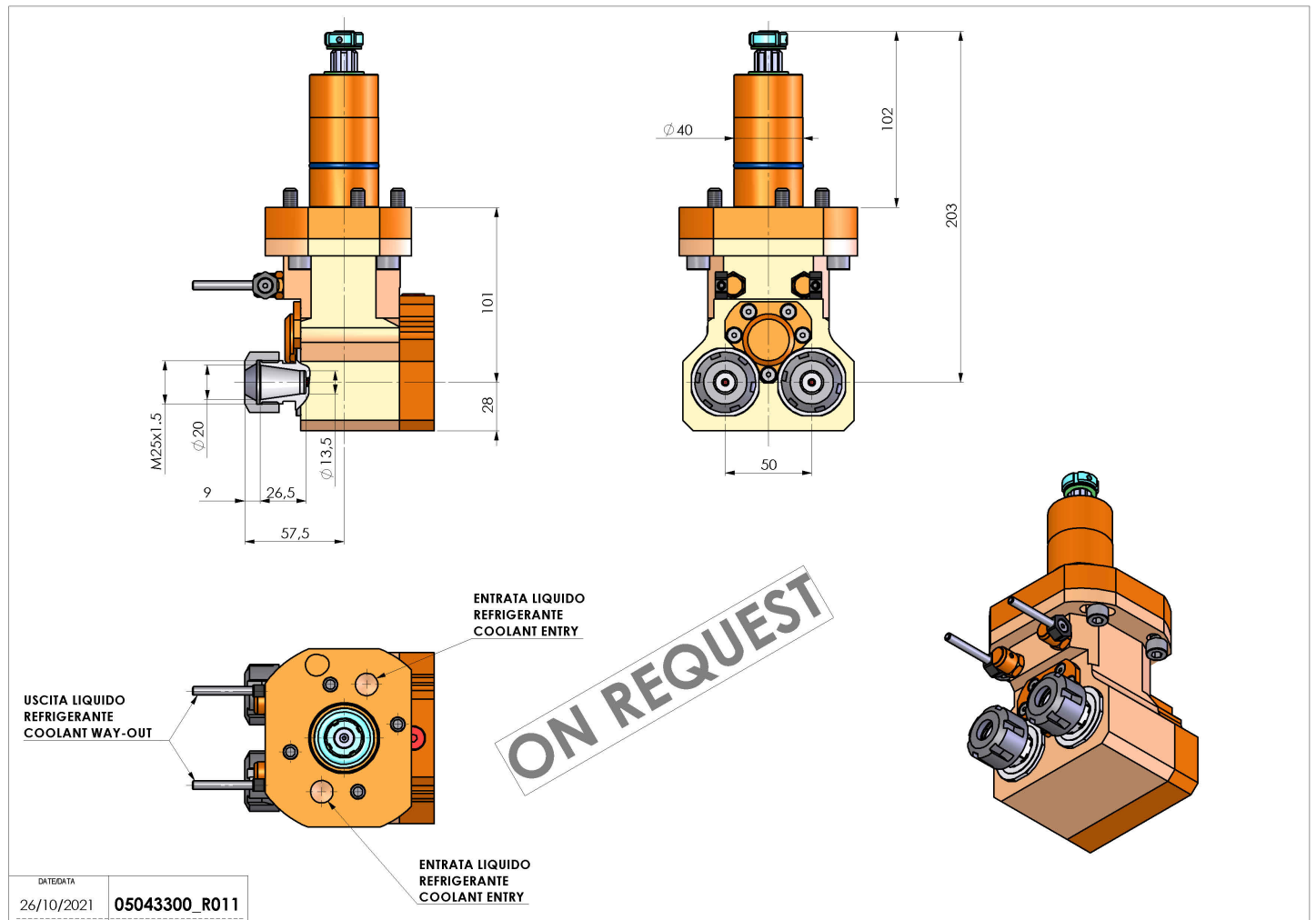

DATE DATA
26/10/2021 **05043300_R011**

Subject to technical changes