

05043000 - LUNETTA VDI30 H130

Type	STEADY REST Self-centering steady rest for turret
Mounting	VDI 30
Tool output	Gripping jaws Ø5-Ø60
Coolant	N.A.
H [mm]	130
Ø Min [mm]	5
Ø Max [mm]	60
Max pressure [bar]	14
Accessories	N.A.
Notes	N.A.
Mounting tips	Lower turret

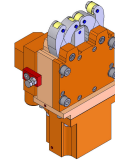

ATTENTION: CHECK THE ORIENTATION OF THE VDI TEETH

Always check live tool dimensions on the turret

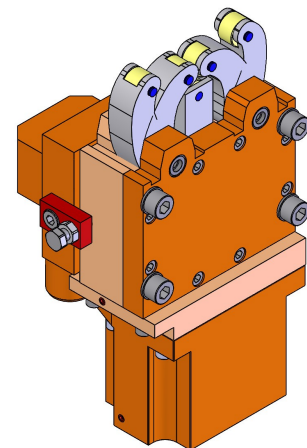
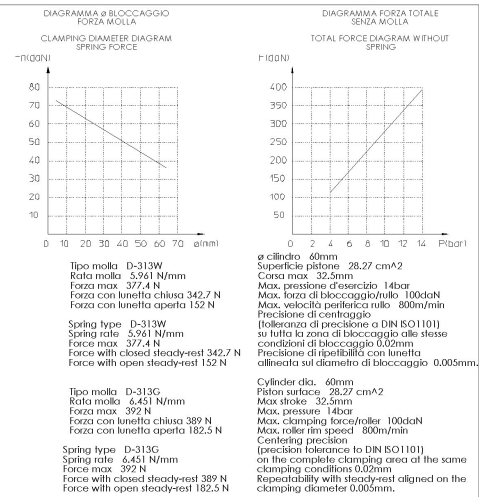
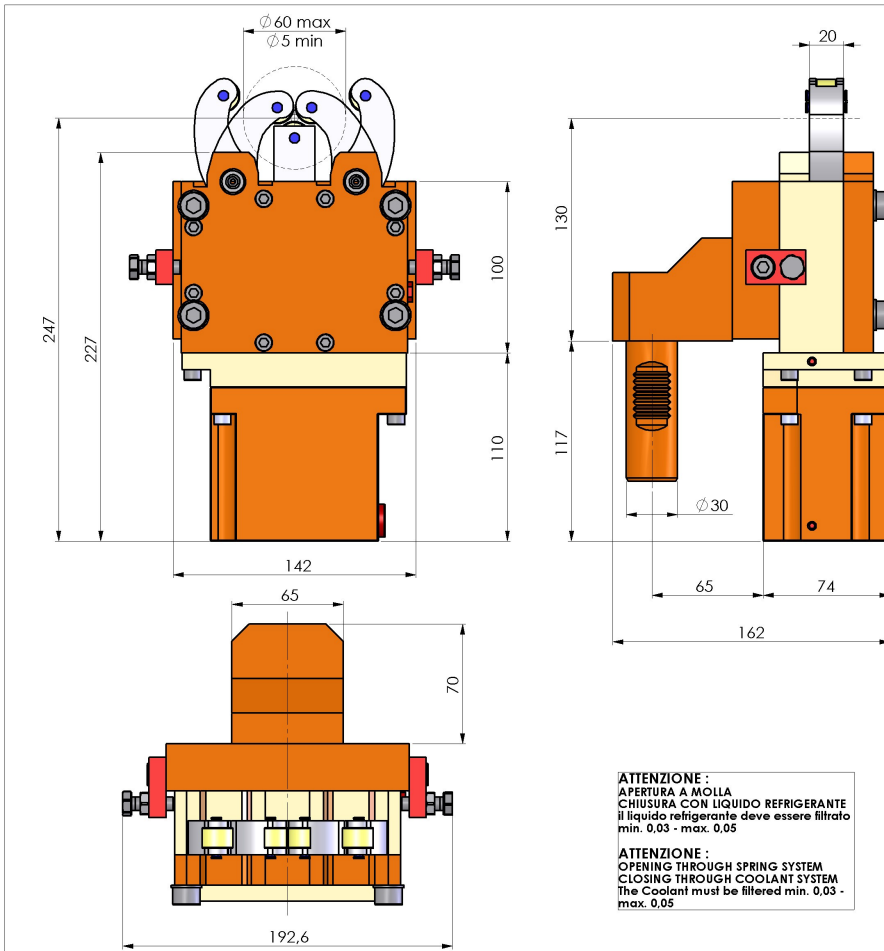

ATTENZIONE :
APERTURA A MOLLA
CHIUSURA CON LIQUIDO REFRIGERANTE
 il liquido refrigerante deve essere filtrato
 min. 0,03 - max. 0,05

ATTENZIONE :
OPENING THROUGH SPRING SYSTEM
CLOSING THROUGH COOLANT SYSTEM
 The Coolant must be filtered min. 0,03 -
 max. 0,05

DATE/DATE
 09/02/2024 05043000-R011

Subject to technical changes