

05042200 - LT-S D60 ER40FOF95RF2:1HS H108

Type	LT-S OFS Tool holder straight offset
Mounting	CYLINDRICAL SHANK 60
Tool output	Collet nut ER 40 F - internal nut
Coolant	Internal coolant
Offset [mm]	95
Direction of rotation	r1 ↻ r2 ↻
Max speed [rpm]	in 10000 / out 5000
Max torque [Nm]	in 63 / out 120
Ratio	2:1
H [mm]	108
Max pressure [bar]	20
Accessories	N.A.
Notes	N.A.
Mounting tips	N.A.

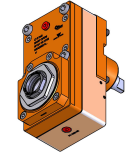

Always check live tool dimensions on the turret

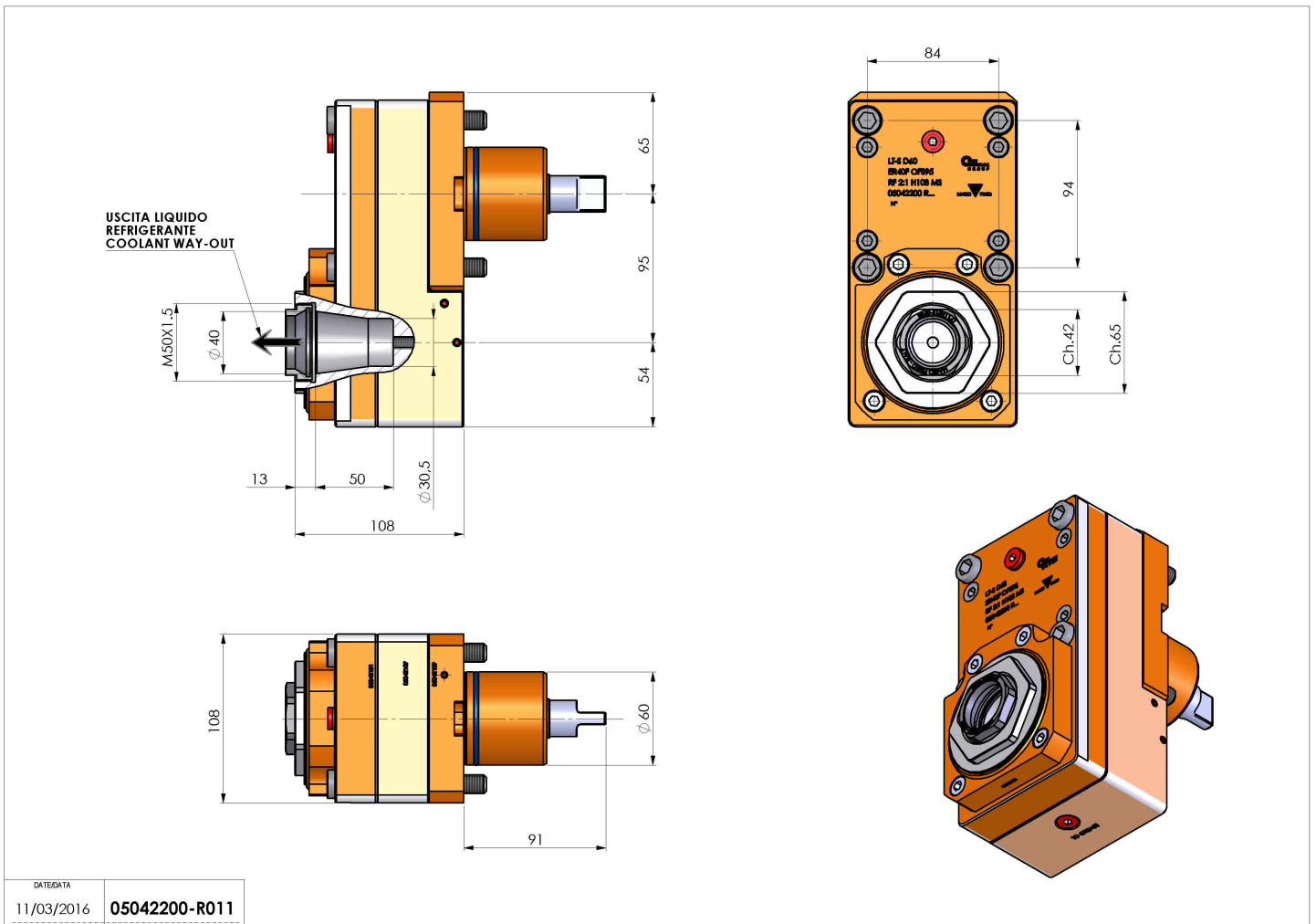

DATE/DATE	11/03/2016
	05042200-R011

Subject to technical changes