

# 05042100 - LT-S D60 ER40FOF95 2:1 HS H108

<b>Type</b>	LT-S OFS Tool holder straight offset
<b>Mounting</b>	CYLINDRICAL SHANK 60
<b>Tool output</b>	Collet nut ER 40 F - internal nut
<b>Coolant</b>	External coolant
<b>Offset [mm]</b>	95
<b>Direction of rotation</b>	r1 ↻ r2 ↻
<b>Max speed [rpm]</b>	in 10000 / out 5000
<b>Max torque [Nm]</b>	in 63 / out 120
<b>Ratio</b>	2:1
<b>H [mm]</b>	108
<b>Accessories</b>	N.A.
<b>Notes</b>	N.A.
<b>Mounting tips</b>	N.A.

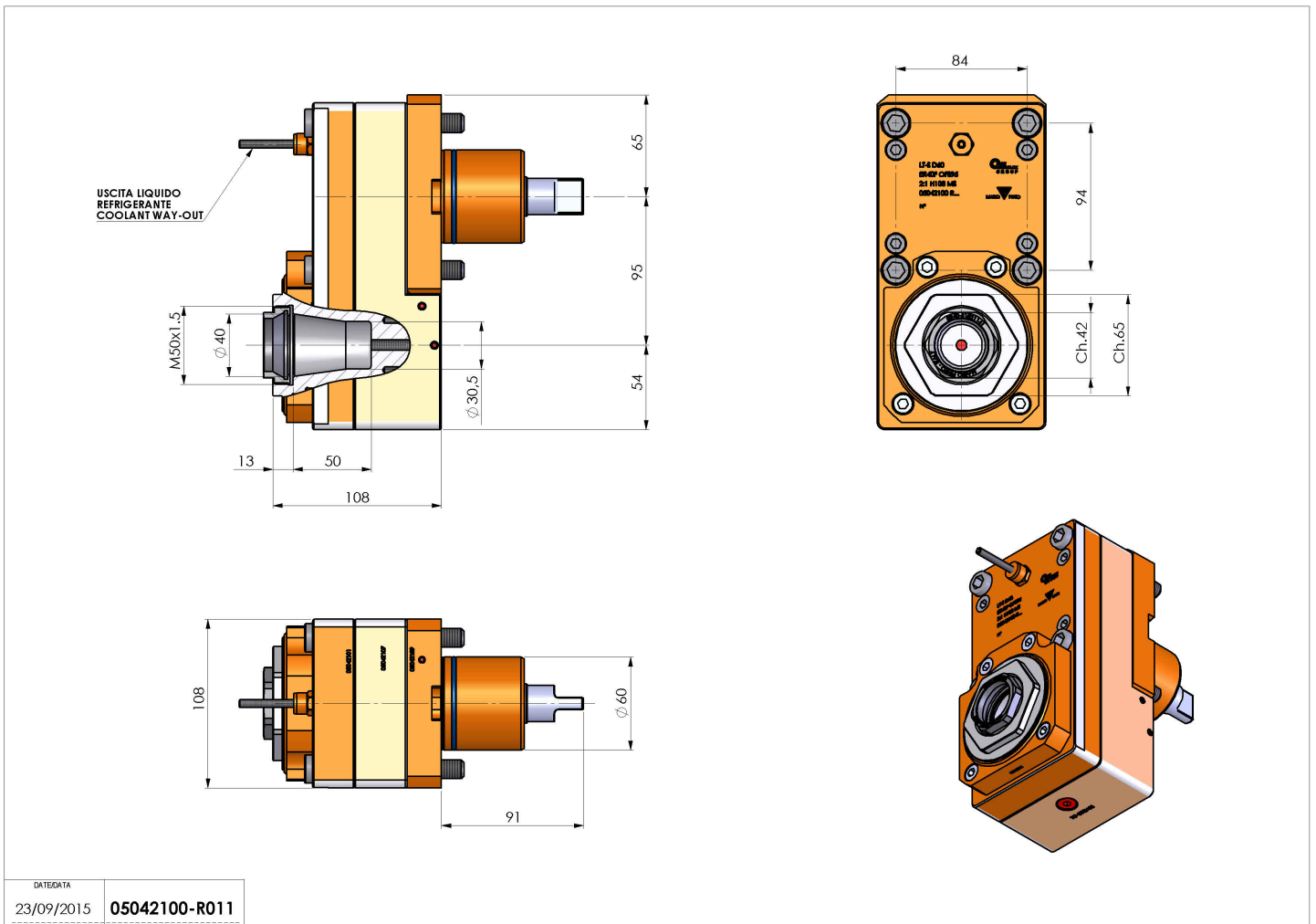

Always check live tool dimensions on the turret



DATE/DATA	05042100-R011
23/09/2015	

Subject to technical changes