

05042000 - LT-S2 D60 ER20F-20F 1:2 H111

Type	LT-S2 Tool holder double straight
Mounting	CYLINDRICAL SHANK 60
Tool output	Collet nut ER 20 F - internal nut
Coolant	External coolant
Direction of rotation	r1 ↻ r2 ↻ r3 ↻
Max speed [rpm]	in 6000 / out 12000
Max torque [Nm]	in 38 / out 16
Ratio	1:2
H [mm]	111
Accessories	N.A.
Notes	N.A.
Mounting tips	N.A.

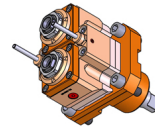

Always check live tool dimensions on the turret

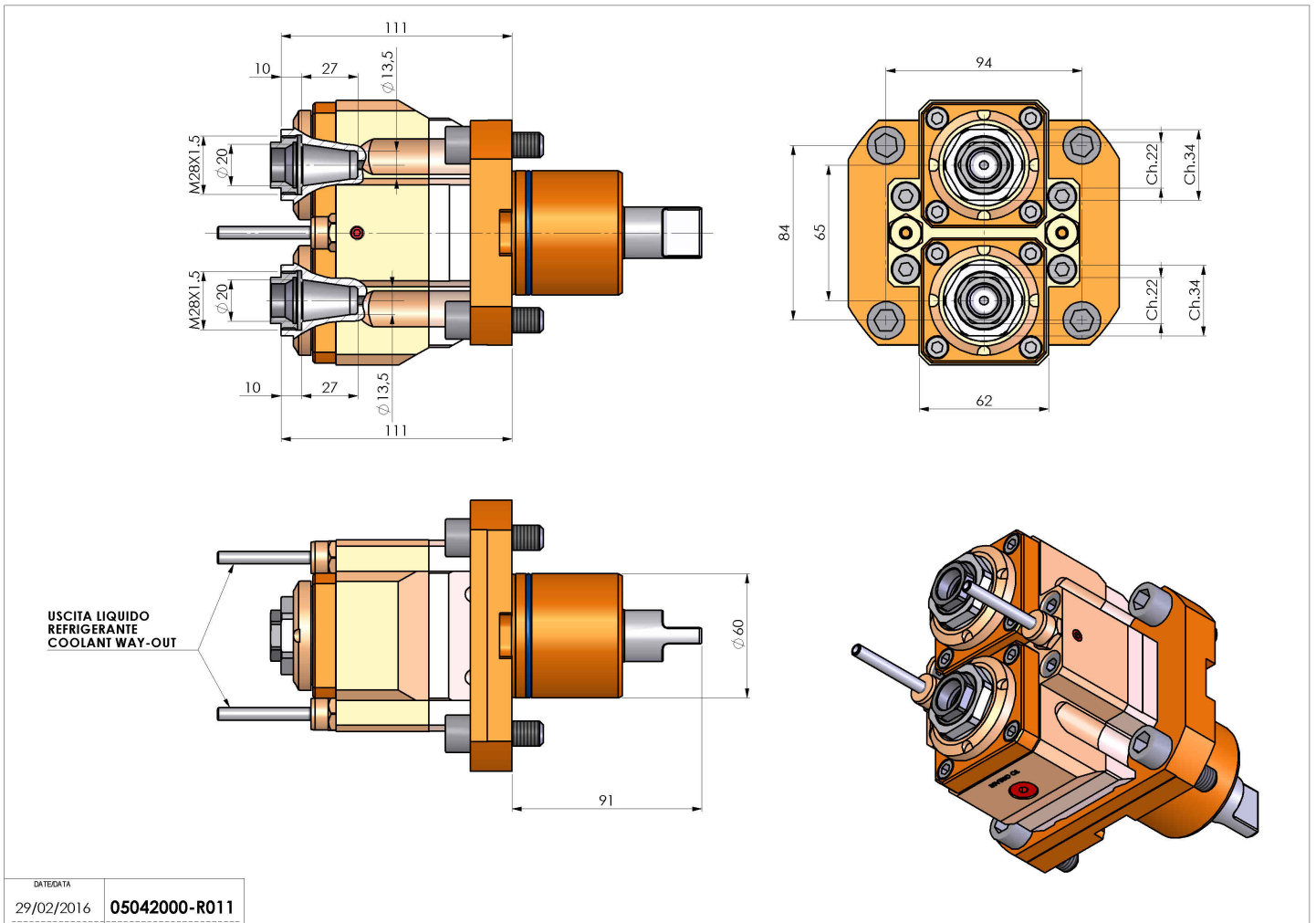

DATE/DATE	05042000-R011
29/02/2016	

Subject to technical changes