

05037100 - LT-S D50 ER32 H75 TW

Type	LT-S Tool holder straight
Mounting	CYLINDRICAL SHANK 50
Tool output	Collet nut ER 32
Coolant	External coolant
Direction of rotation	r1 ↻ r2 ↻
Max speed [rpm]	6000
Max torque [Nm]	63
Ratio	1:1
H [mm]	75
Accessories	
Notes	N.A.
Mounting tips	N.A.

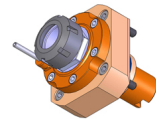

Always check live tool dimensions on the turret

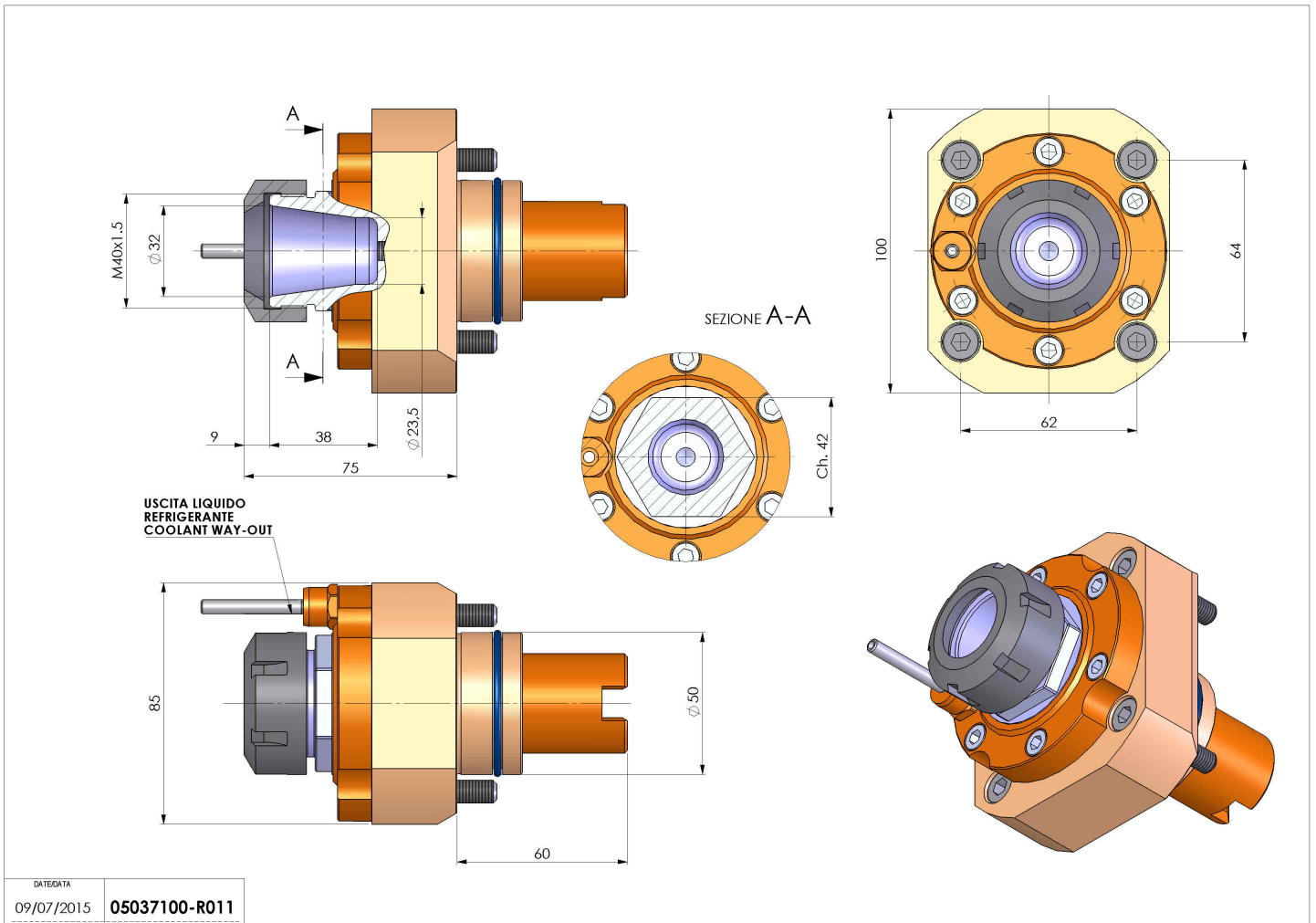

DATE/DATE	09/07/2015	05037100-R011
-----------	------------	---------------

Subject to technical changes