

05034000 - LT-T D60 ER16F H59-128 TW

Type	LT-T Tool holder tiltable
Mounting	CYLINDRICAL SHANK 60
Tool output	Collet nut ER 16 F - internal nut
Coolant	External coolant
Direction of rotation	r1 ↻ r2 ↻
Max speed [rpm]	6000
Max torque [Nm]	10
Ratio	1:1
H [mm]	90-159
Accessories	N.A.
Notes	N.A.
Mounting tips	N.A.

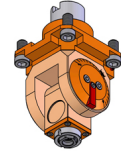

Always check live tool dimensions on the turret

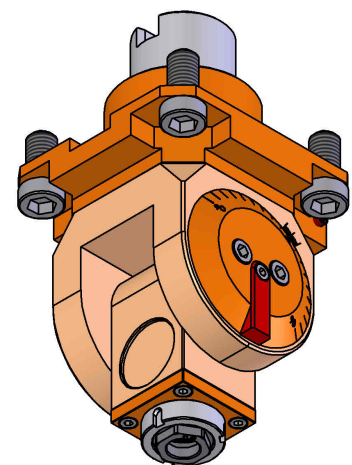
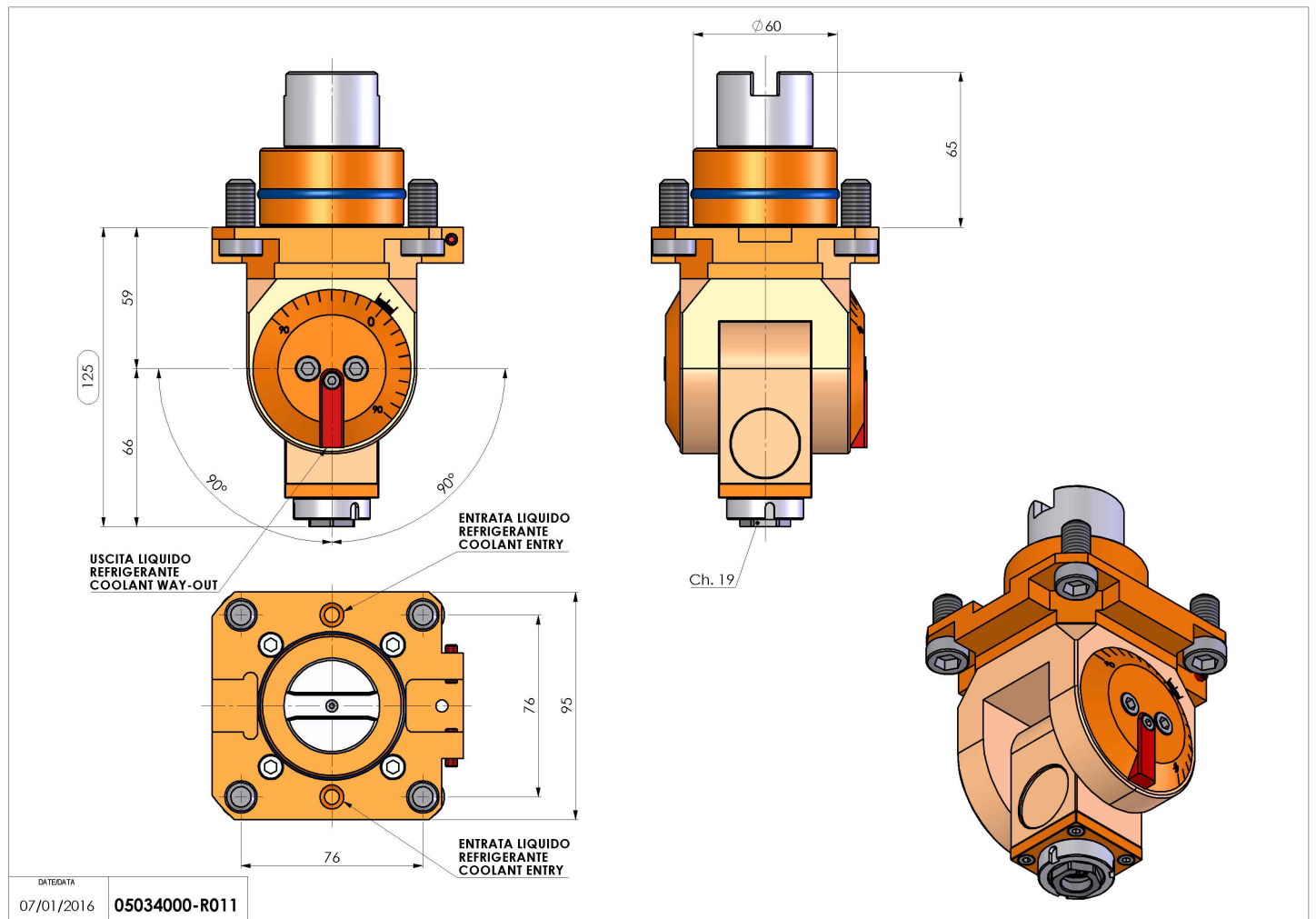

Subject to technical changes

DATE/DATE: 07/01/2016
05034000-R011