

## 05033200 - LT-A VDI40 C40 HRF LR H90 TW

Type	LT-A Tool holder angle 90°
Mounting	VDI 40
Tool output	Polygonal shank C40 ISO 26623-1
Coolant	HRF Internal coolant
Direction of rotation	r1 ↻ r2 ↻
Max speed [rpm]	6000
Max torque [Nm]	63
Ratio	1:1
H [mm]	90
H1 [mm]	41
Max pressure [bar]	80
Accessories	N.A.
Notes	N.A.
Mounting tips	N.A.

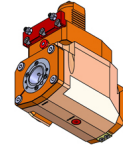

**ATTENTION: CHECK THE ORIENTATION OF THE VDI TEETH**

Always check live tool dimensions on the turret

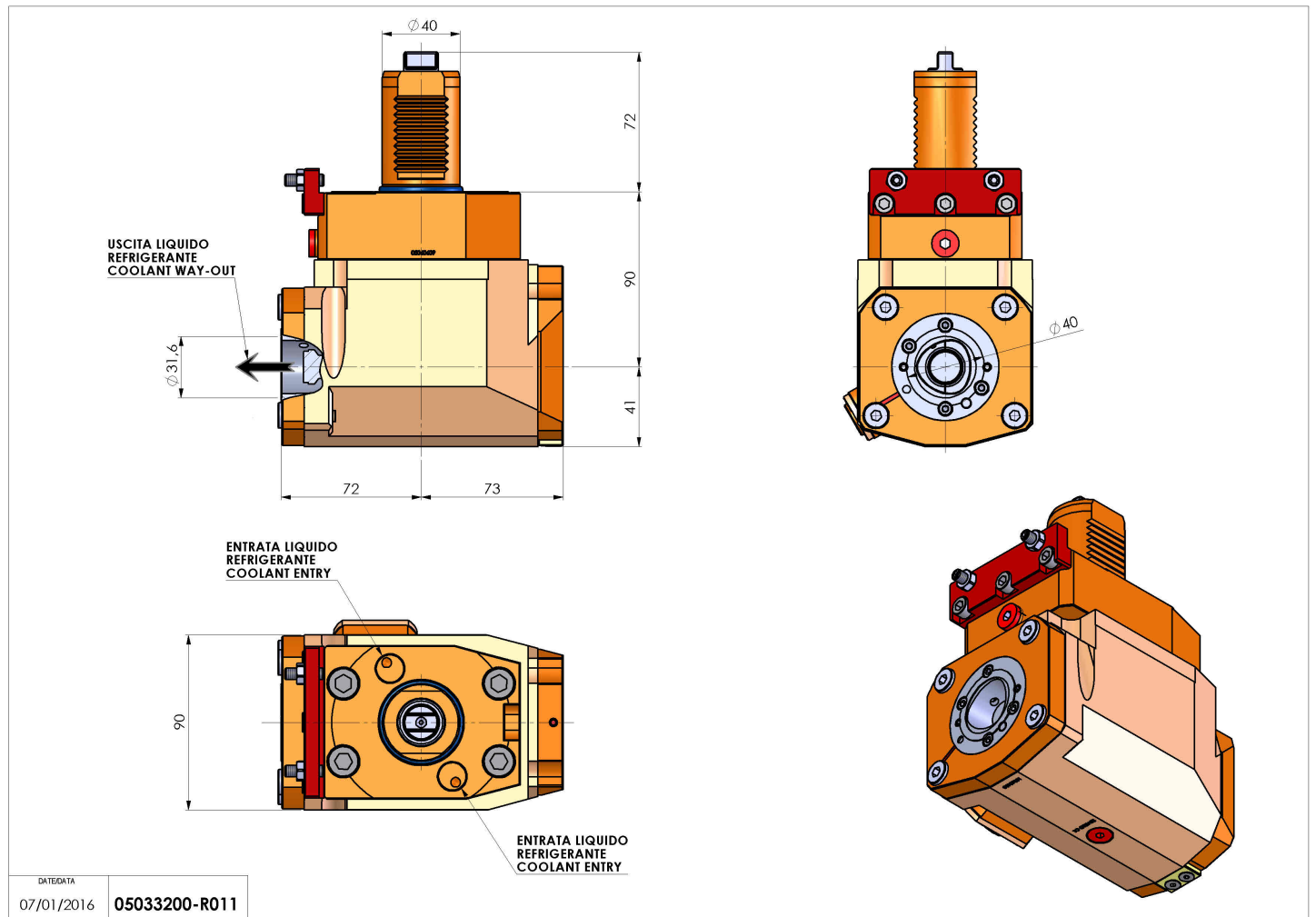

DATE/DATE: 07/01/2016  
05033200-R011

Subject to technical changes