

# 05025400 - LT-A VDI30 ER25F R H75 TZ

Type	LT-A Tool holder angle 90°
Mounting	VDI 30
Tool output	Collet nut ER 25 F - internal nut
Coolant	External coolant
Direction of rotation	r1 ↻ r2 ↻
Max speed [rpm]	6000
Max torque [Nm]	30
Ratio	1:1
H [mm]	75
H1 [mm]	32,5
Accessories	N.A.
Notes	N.A.
Mounting tips	Main spindle only

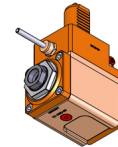

**ATTENTION: CHECK THE ORIENTATION OF THE VDI TEETH**

Always check live tool dimensions on the turret

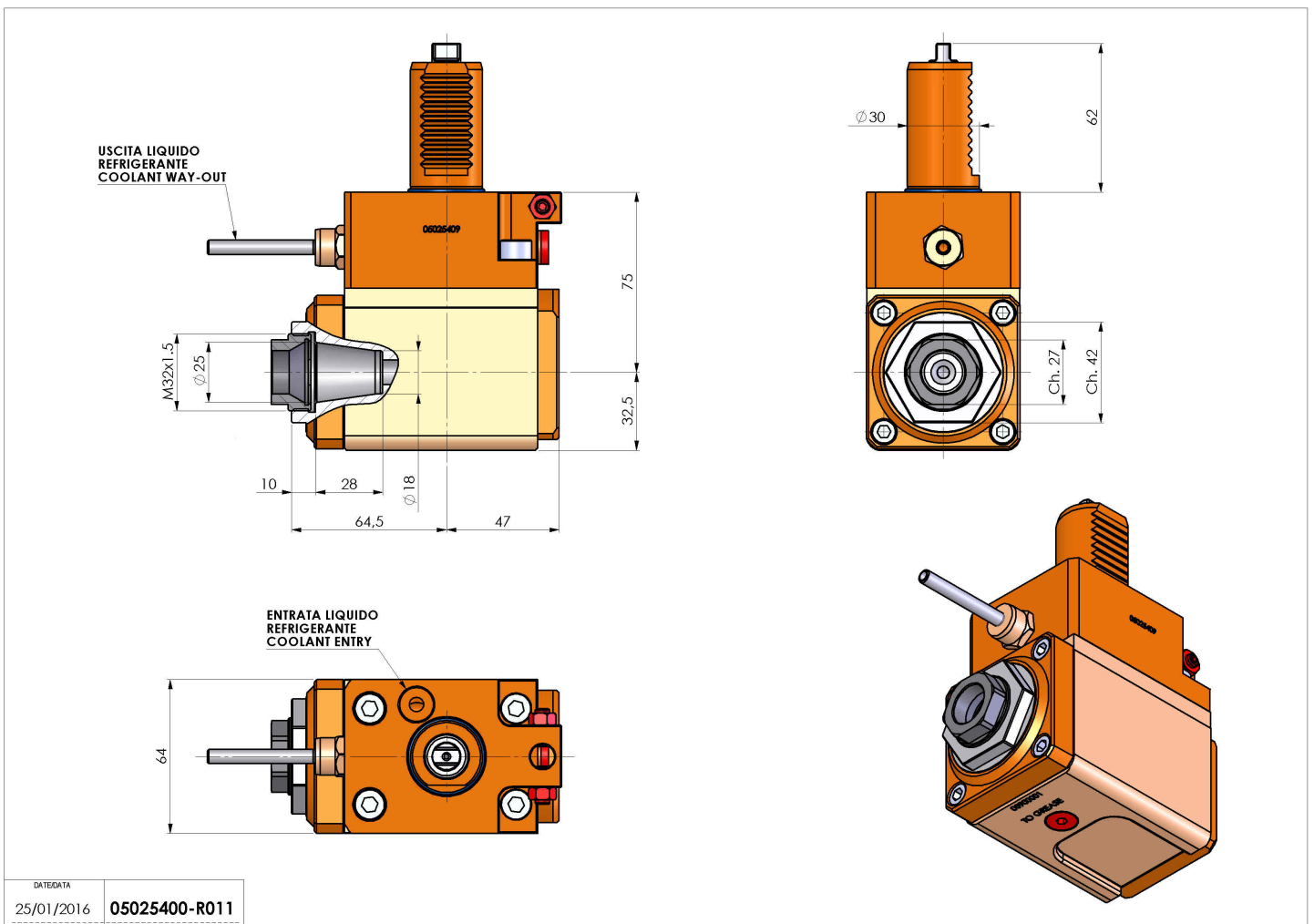

DATE/ATA	05025400-R011
25/01/2016	

Subject to technical changes