

05020800 - LT-A VDI30 ER25 R H75 TAKAMAZ

Type	LT-A OFS Tool holder offset angle 90°
Mounting	VDI 30
Tool output	Collet nut ER 25
Coolant	External coolant
Direction of rotation	r1 ↻ r2 ↻
Max speed [rpm]	6000
Max torque [Nm]	25
Ratio	1:1
H [mm]	75
H1 [mm]	29
Accessories	N.A.
Notes	N.A.
Mounting tips	Main spindle only

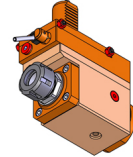

ATTENTION: CHECK THE ORIENTATION OF THE VDI TEETH

Always check live tool dimensions on the turret

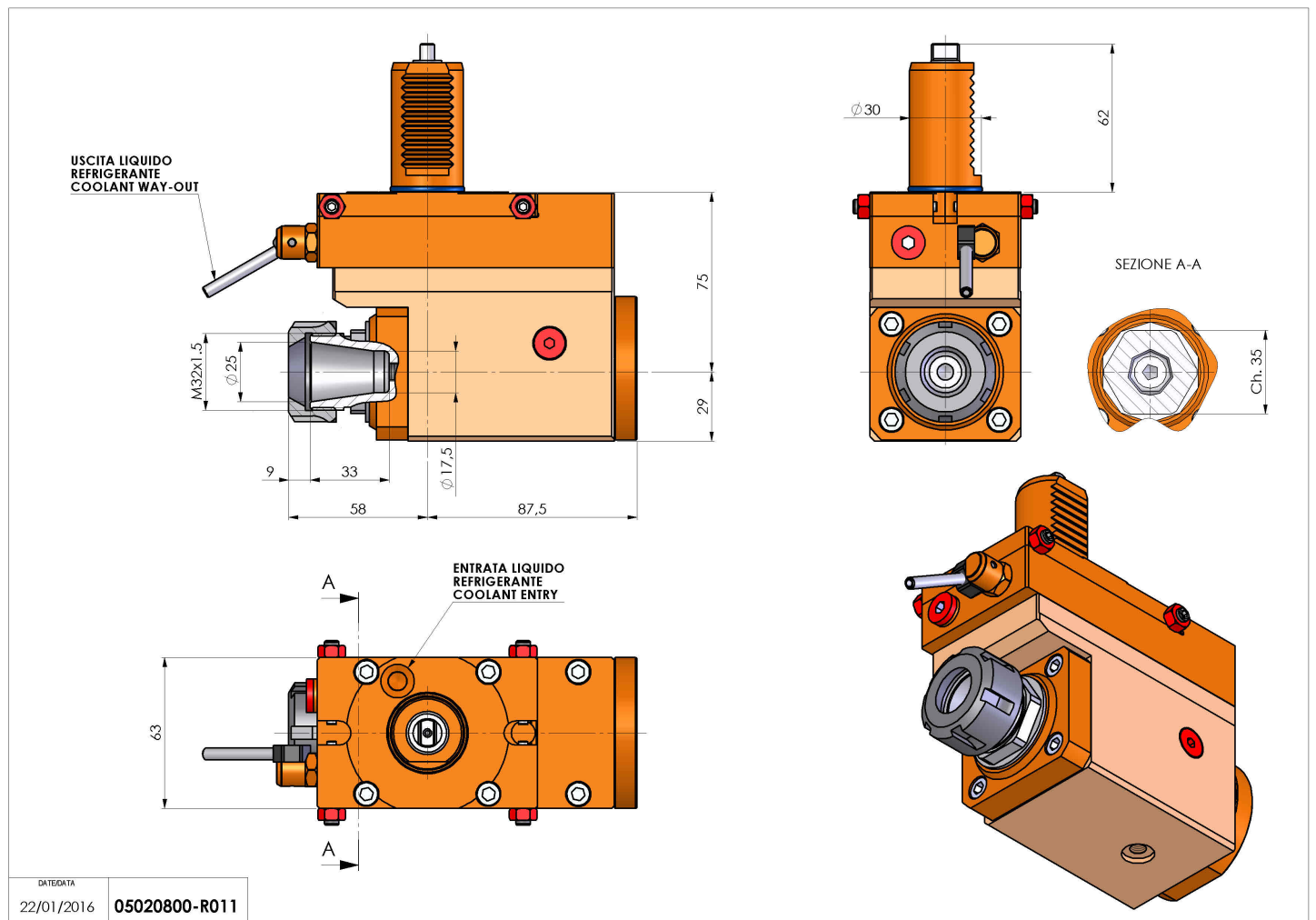

Subject to technical changes