

05020100 - LT-SVDI30ER20FROFS78RFX3H88 TZ

Type	LT-S OFS Tool holder straight offset
Mounting	VDI 30
Tool output	Collet nut ER 20 F - internal nut
Coolant	Internal coolant
Offset [mm]	78
Direction of rotation	r1 ↻ r2 ↻
Max speed [rpm]	in 5000 / out 15000
Max torque [Nm]	in 50 / out 14
Ratio	1:3
H [mm]	88,5
Max pressure [bar]	20
Accessories	N.A.
Notes	N.A.
Mounting tips	Main spindle only

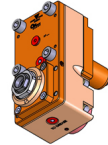

ATTENTION: CHECK THE ORIENTATION OF THE VDI TEETH

Always check live tool dimensions on the turret

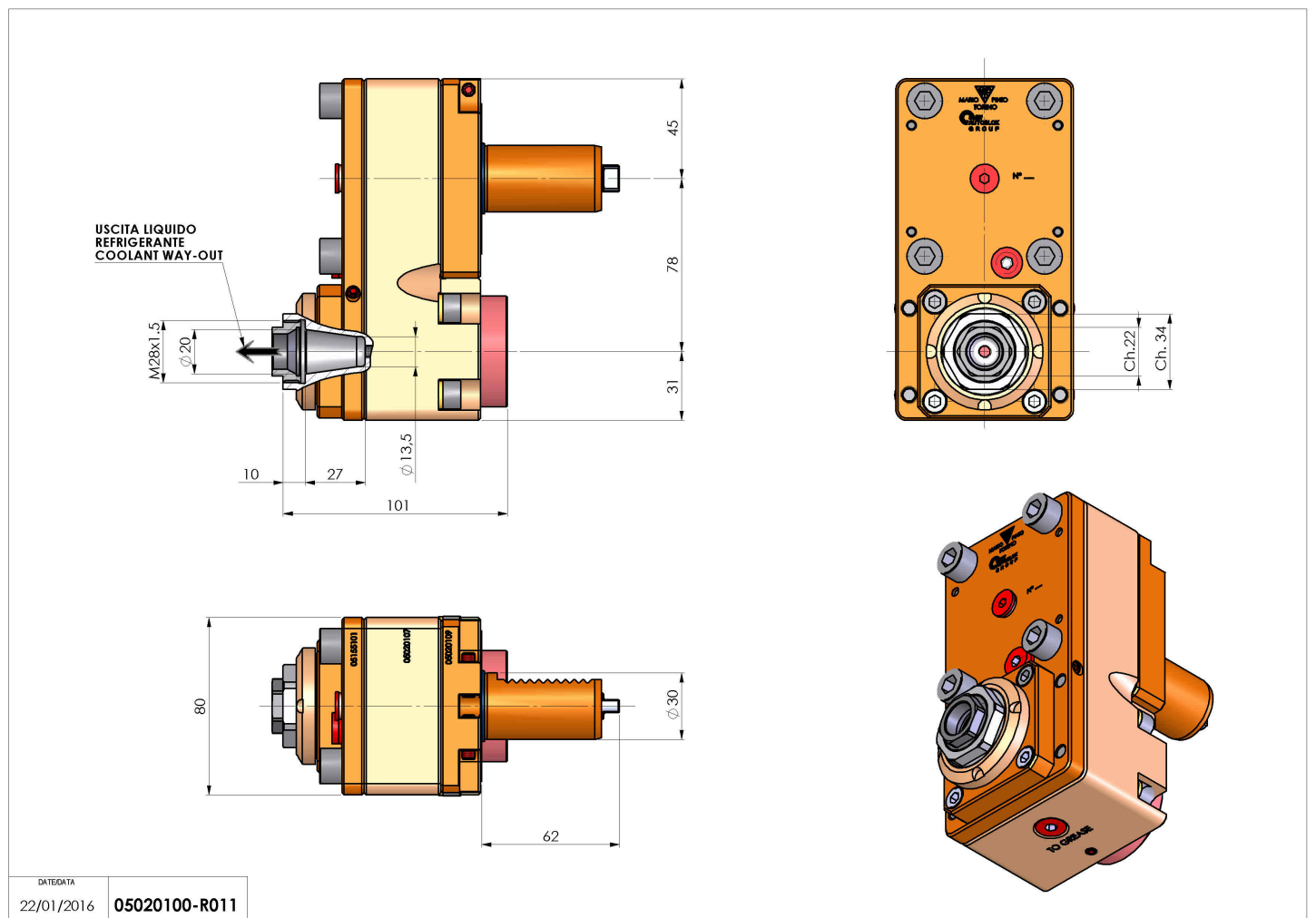

DATE/DATE	22/01/2016	05020100-R011
-----------	------------	---------------

Subject to technical changes