

# 05017300 - LT-A D55 ER32F RF 2:1 H65 NK

Type	LT-A Tool holder angle 90°
Mounting	CYLINDRICAL SHANK 55
Tool output	Collet nut ER 32 F - internal nut
Coolant	Internal coolant
Direction of rotation	r1 ↻ r2 ↻
Max speed [rpm]	in 6000 / out 3000
Max torque [Nm]	in 40 / out 80
Ratio	2:1
H [mm]	65
H1 [mm]	36
Max pressure [bar]	20
Accessories	N.A.
Notes	N.A.
Mounting tips	N.A.

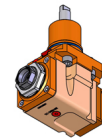

Always check live tool dimensions on the turret

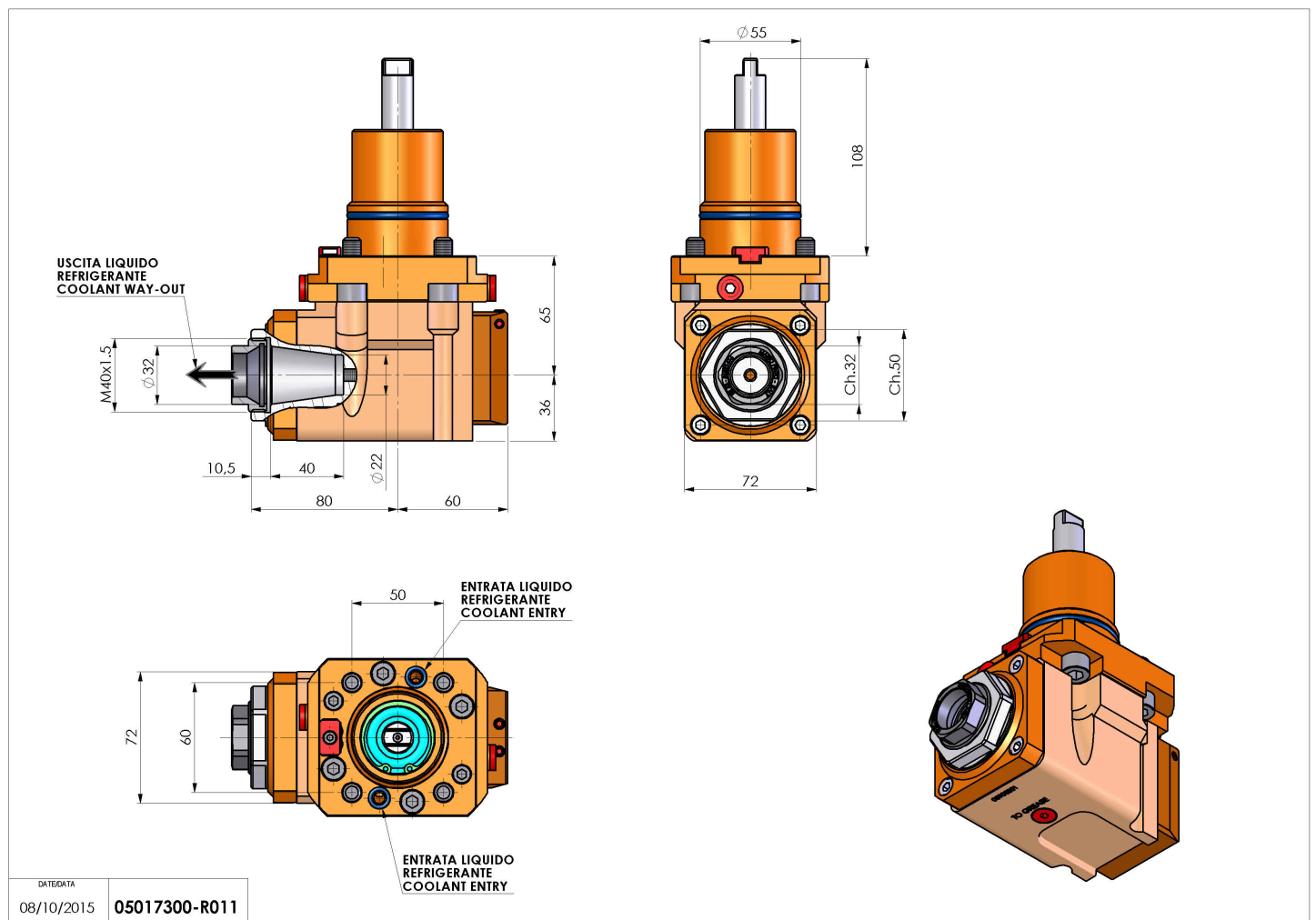

Subject to technical changes