

# 05016800 - LT-S2 D55 ER16F-16F 1:1 H75 NK

|                              |                                      |
|------------------------------|--------------------------------------|
| <b>Type</b>                  | LT-S2<br>Tool holder double straight |
| <b>Mounting</b>              | CYLINDRICAL SHANK 55                 |
| <b>Tool output</b>           | Collet nut ER 16 F - internal nut    |
| <b>Coolant</b>               | External coolant                     |
| <b>Direction of rotation</b> | r1 ↻ r2 ↻ r3 ↻                       |
| <b>Max speed [rpm]</b>       | 6000                                 |
| <b>Max torque [Nm]</b>       | 15                                   |
| <b>Ratio</b>                 | 1:1                                  |
| <b>H [mm]</b>                | 75                                   |
| <b>Accessories</b>           | N.A.                                 |
| <b>Notes</b>                 | N.A.                                 |
| <b>Mounting tips</b>         | N.A.                                 |

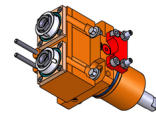

Always check live tool dimensions on the turret

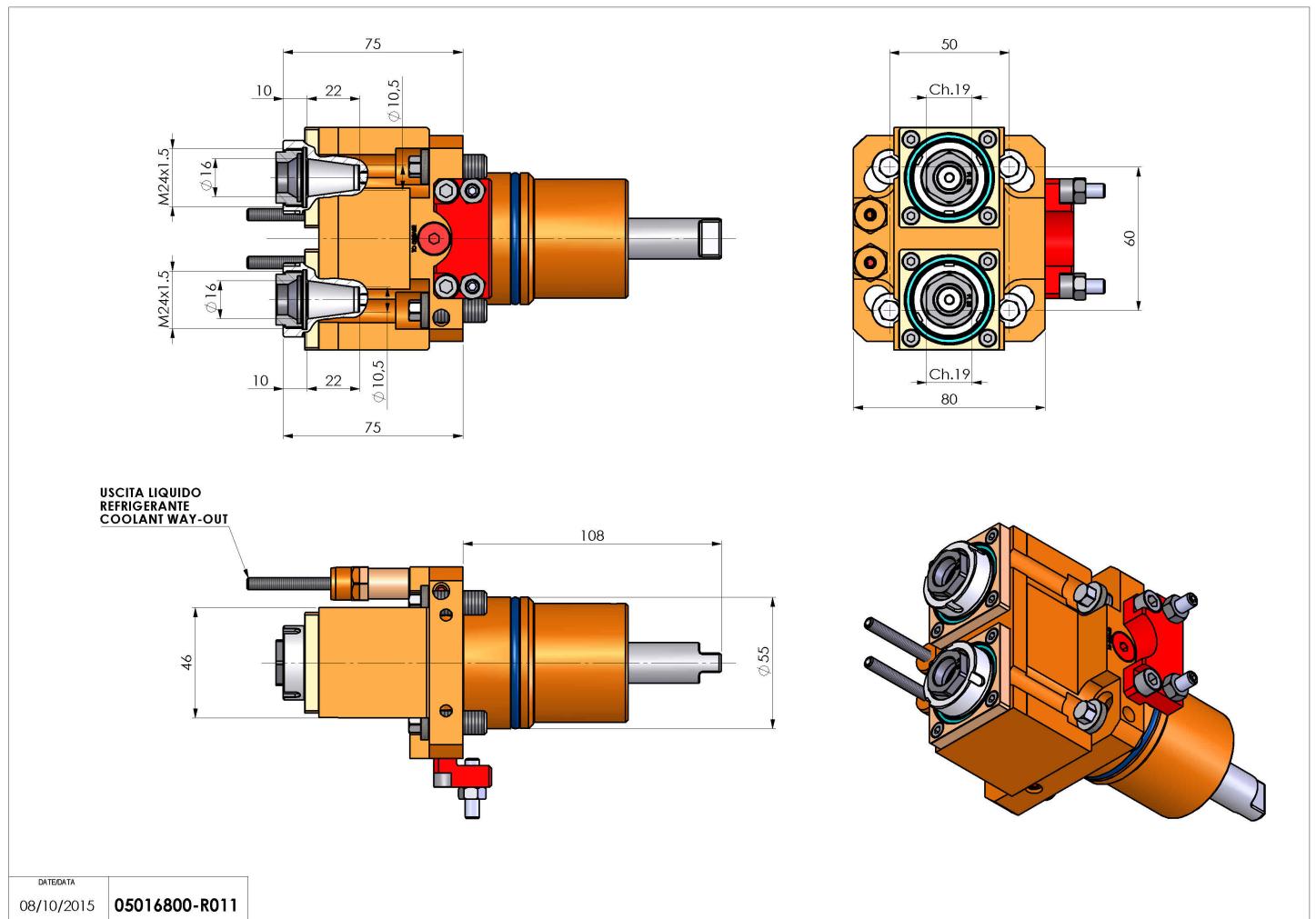

Subject to technical changes