

05016100 - LT-SD55ER32FOFS76 HRF H106NK

Type	LT-S OFS Tool holder straight offset
Mounting	CYLINDRICAL SHANK 55
Tool output	Collet nut ER 32 F - internal nut
Coolant	HRF Internal coolant
Offset [mm]	76
Direction of rotation	r1 ↻ r2 ↻
Max speed [rpm]	6000
Max torque [Nm]	63
Ratio	1:1
H [mm]	106
Max pressure [bar]	80
Accessories	N.A.
Notes	N.A.
Mounting tips	N.A.

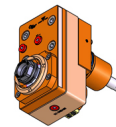

Always check live tool dimensions on the turret

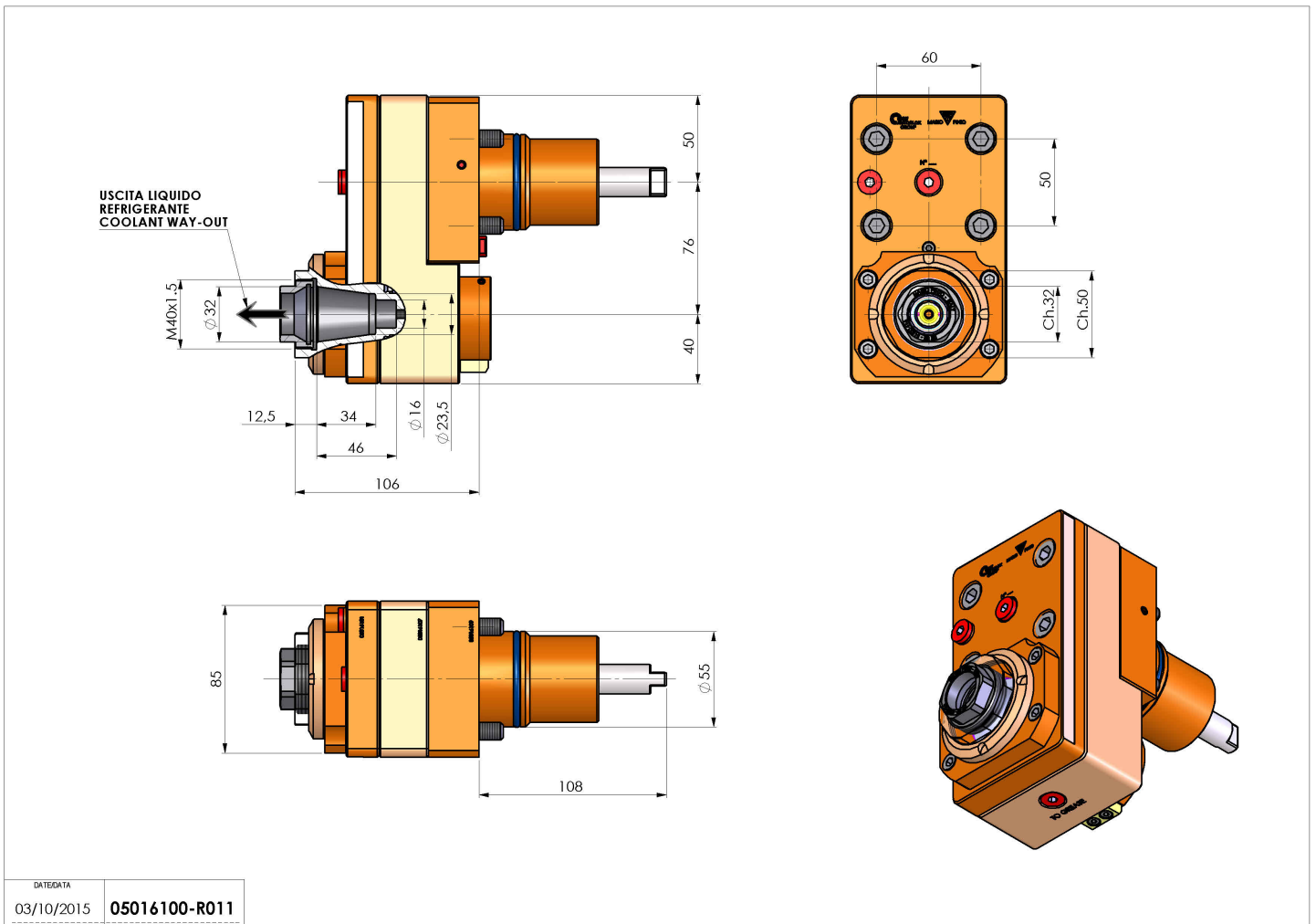

DATE/DATE	03/10/2015	05016100-R011
-----------	------------	---------------

Subject to technical changes