

05014100 - LT-A ST25 D44 C12 H75 NK

Type	LT-A ST Slotting tool 90°
Mounting	CYLINDRICAL SHANK 44
Tool output	Tool diameter 12
Coolant	External coolant
Max speed [rpm]	700
Max torque [Nm]	17,5
Ratio	1:1
Y axis adjustment	NO
Feed pushing [N]	1000
Stroke [mm]	25
Work stroke [mm]	20
H [mm]	75
Accessories	N.A.
Notes	N.A.
Mounting tips	N.A.

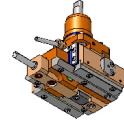

Always check live tool dimensions on the turret

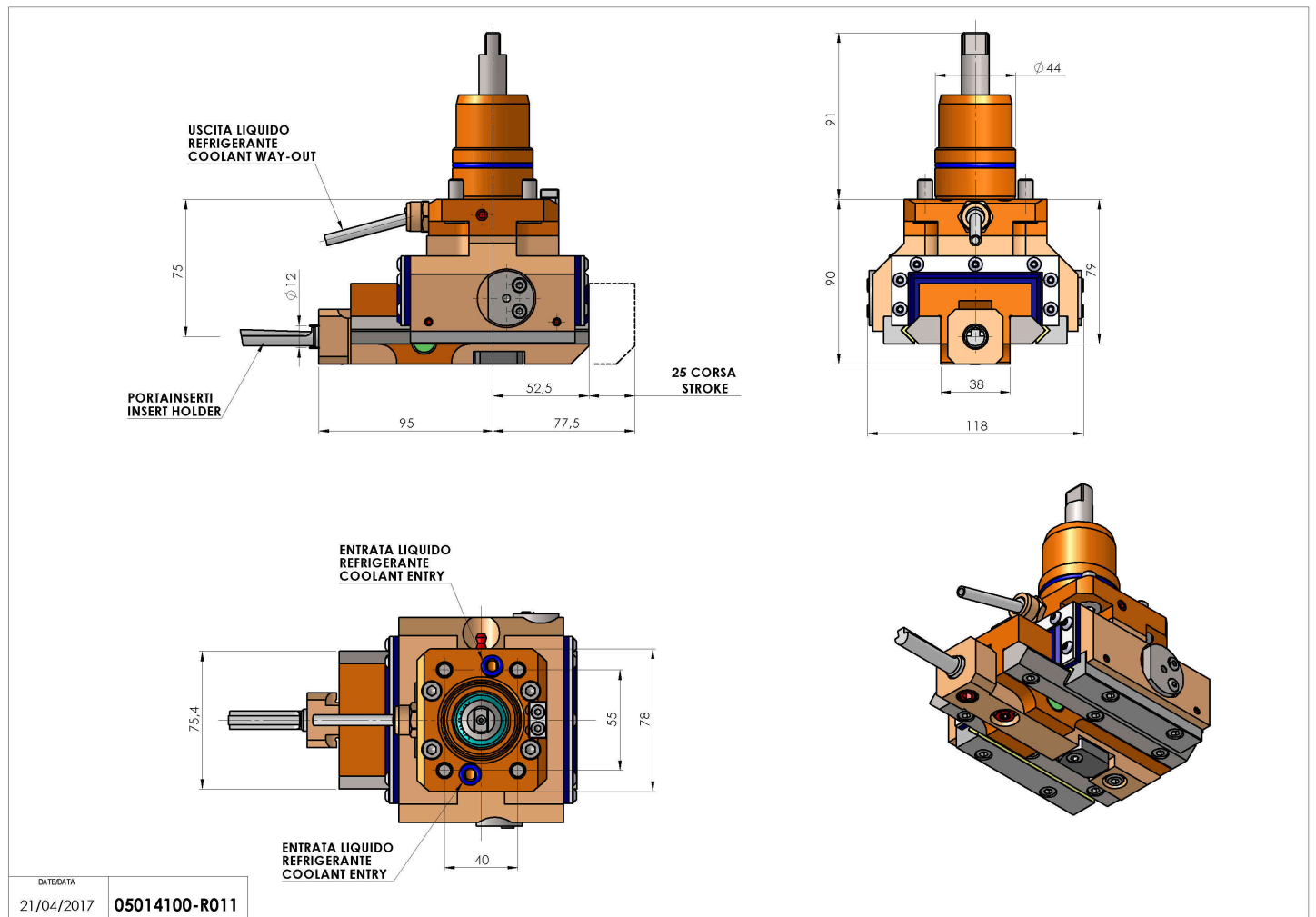

DATE/DATE
21/04/2017
05014100-R011

Subject to technical changes