

05013000 - LT-A D65 ER32F RF LR H65 NK

Type	LT-A Tool holder angle 90°
Mounting	CYLINDRICAL SHANK 65
Tool output	Collet nut ER 32 F - internal nut
Coolant	Internal coolant
Direction of rotation	r1 ↻ r2 ↻
Max speed [rpm]	6000
Max torque [Nm]	63
Ratio	1:1
H [mm]	65
H1 [mm]	38
Max pressure [bar]	20
Accessories	N.A.
Notes	N.A.
Mounting tips	N.A.

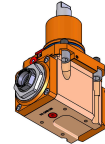

Always check live tool dimensions on the turret

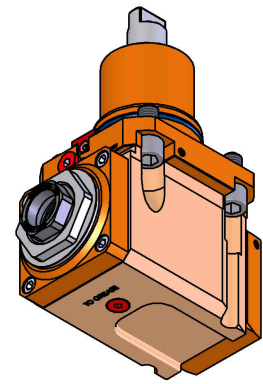
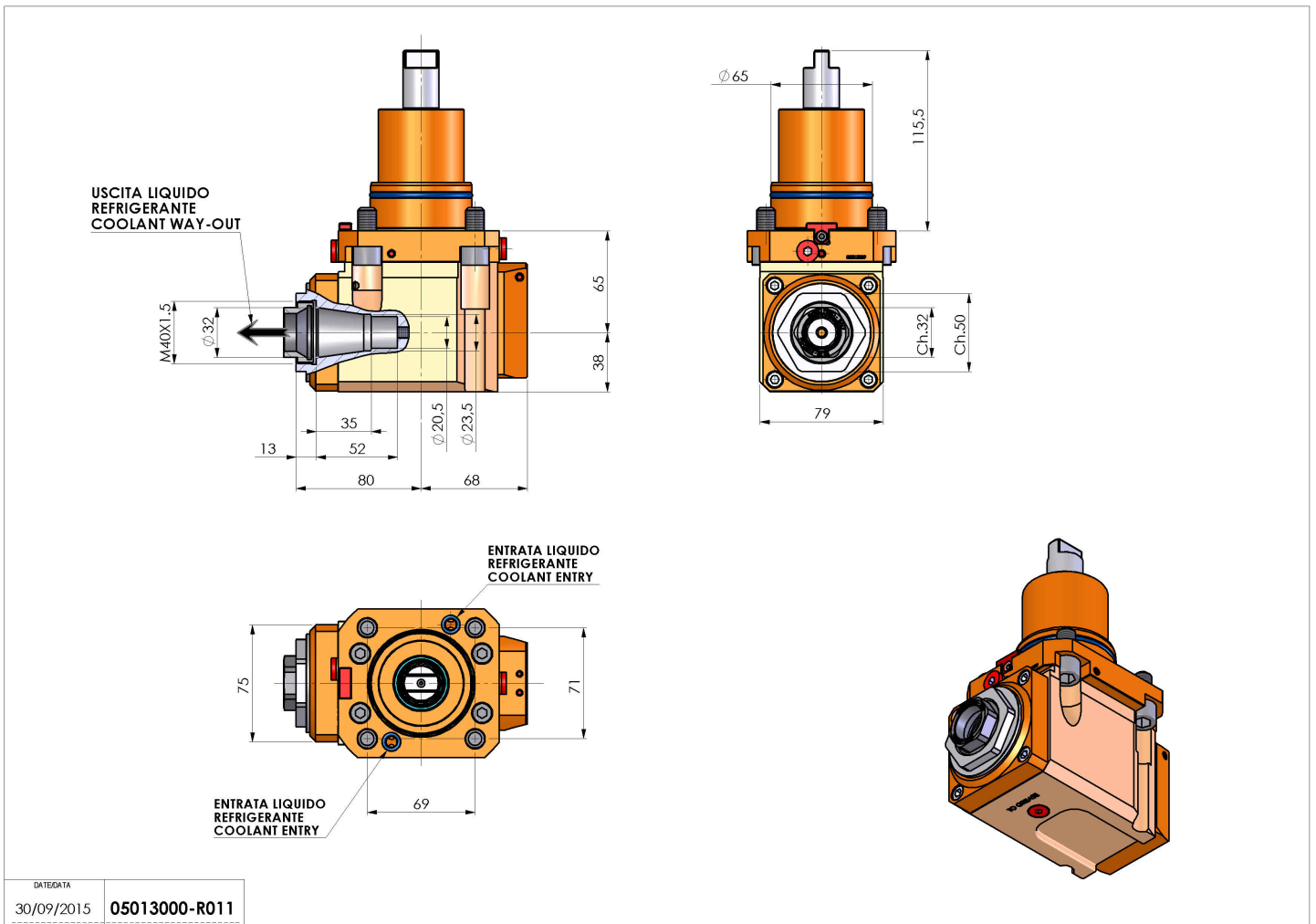

DATE/DATE	30/09/2015
05013000-R011	

Subject to technical changes