

# 05010600 - LT-S D55 ER32 H67.5 NK

<b>Type</b>	LT-S Tool holder straight
<b>Mounting</b>	CYLINDRICAL SHANK 55
<b>Tool output</b>	Collet nut ER 32
<b>Coolant</b>	External coolant
<b>Direction of rotation</b>	r1  r2
<b>Max speed [rpm]</b>	6000
<b>Max torque [Nm]</b>	63
<b>Ratio</b>	1:1
<b>H [mm]</b>	67,5
<b>Accessories</b>	
<b>Notes</b>	N.A.
<b>Mounting tips</b>	N.A.

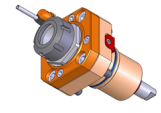

Always check live tool dimensions on the turret

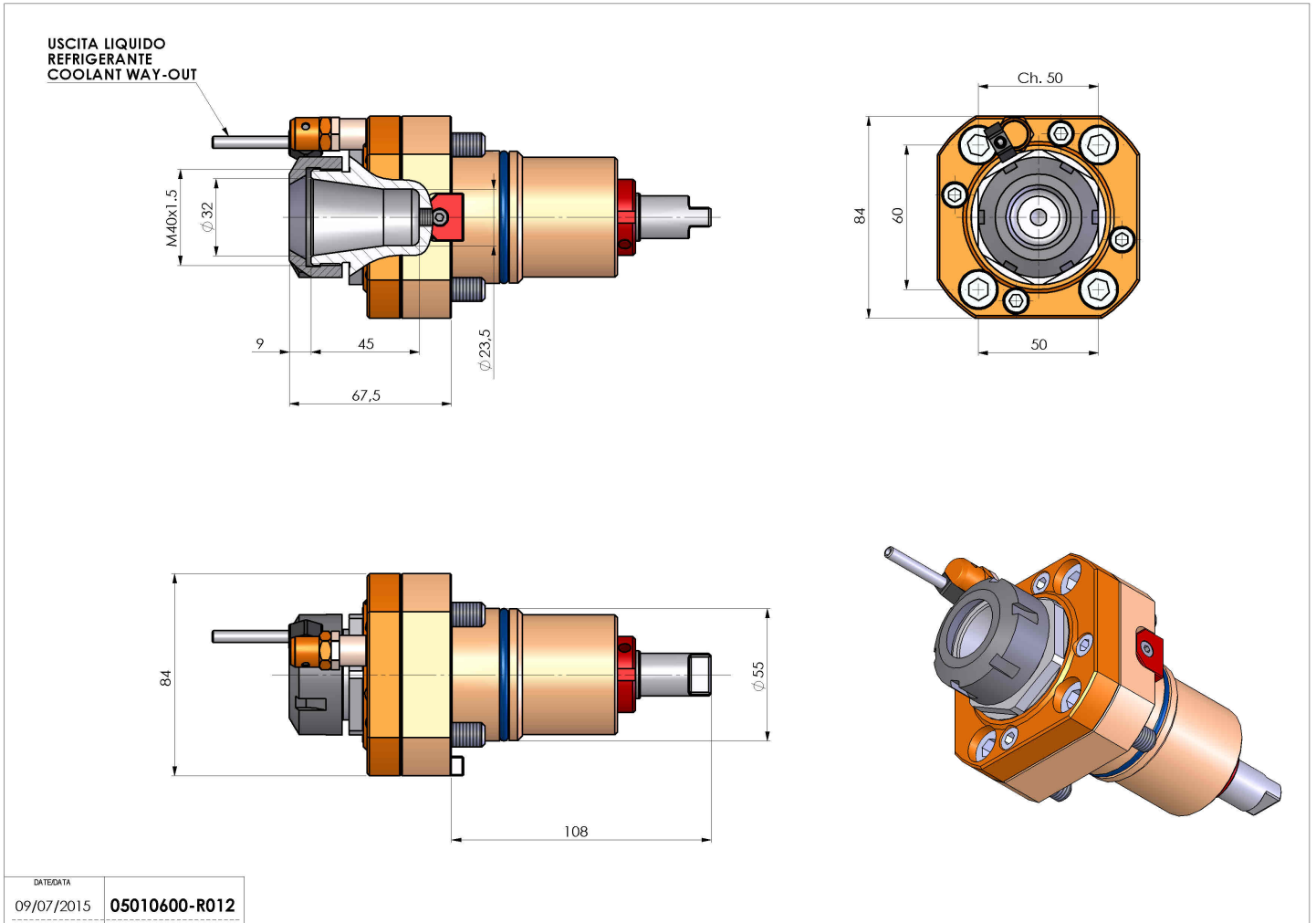

DATE/DATA  
09/07/2015 05010600-R012

Subject to technical changes