

05010300 - LT-S D55 ER32F RF H52 NK

| | |
|------------------------------|-----------------------------------|
| Type | LT-S Tool holder straight |
| Mounting | CYLINDRICAL SHANK 55 |
| Tool output | Collet nut ER 32 F - internal nut |
| Coolant | Internal coolant |
| Direction of rotation | r1 ↻ r2 ↻ |
| Max speed [rpm] | 6000 |
| Max torque [Nm] | 63 |
| Ratio | 1:1 |
| H [mm] | 52 |
| Max pressure [bar] | 20 |
| Accessories | |
| Notes | N.A. |
| Mounting tips | N.A. |

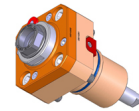

Always check live tool dimensions on the turret

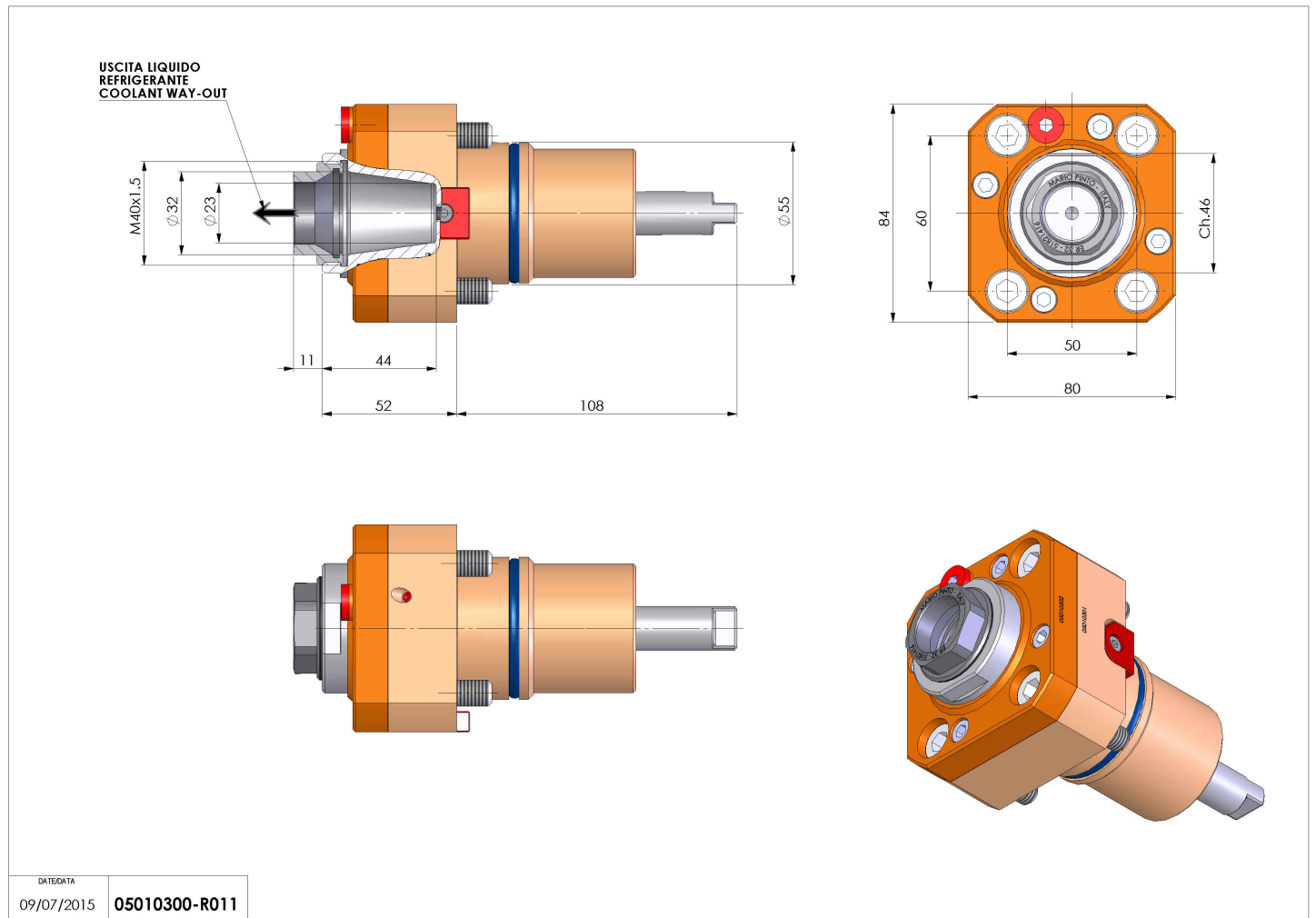

Subject to technical changes